

JK Electronics

1.8 cm (Type 0.71) Active Matrix Color OLED Panel Module

JK0713000SN

1. Description

JK0713000SN 1.8 cm (0.71in_h) diagonal, 1920(RGB) × 1080 dots active matrix color OLED (Organic Light Emitting Display) panel module based on single crystal silicon transistors. The module integrates panel driver and logic driver, and achieves smaller size, light in weight and high resolution. .

(Potential applications: Head mounted displays, View finders, Small monitors etc.)

2. Features

- ◆ Small size and high resolution type 0.70 display
- ◆ Effective dots: 1920 (RGB)×1080 = 6.22 M dots
- ◆ Ultra high contrast
- ◆ Wide color gamut
- ◆ Fast response speed
- ◆ Thin and light in weight
- ◆ Power saving (PS) function
- ◆ Scan direction selection, up or down and right or left.
- ◆ Orbit supported

3. Module Structure

Active matrix color OLED display with on-chip driver based on single crystal silicon transistors

4. System Block Diagram

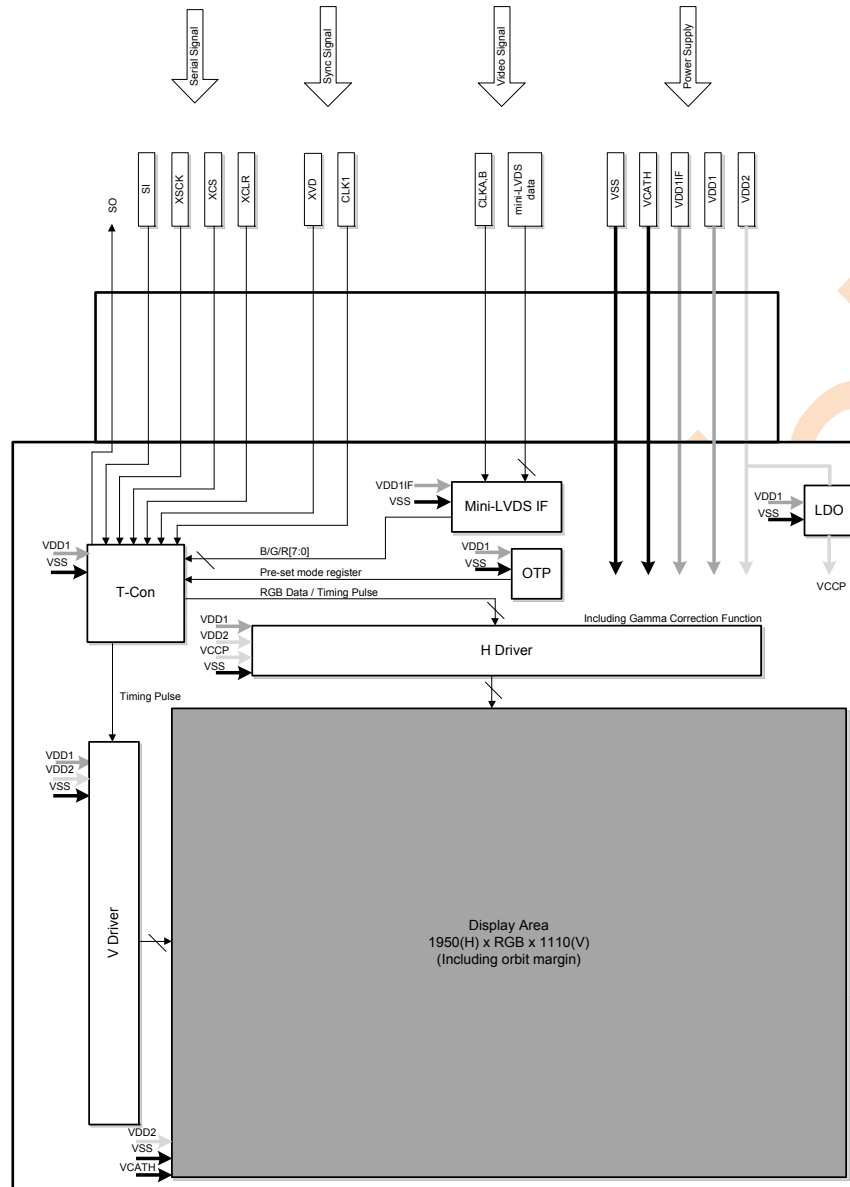

Details of "T-con"

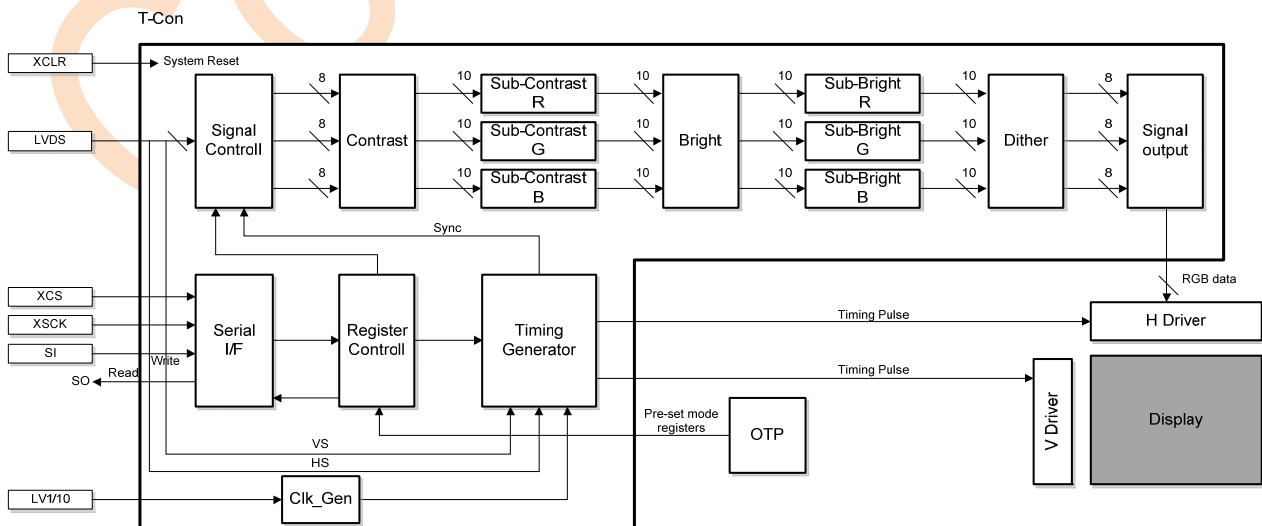

5. Pin Description

5.1 Pin Assignment

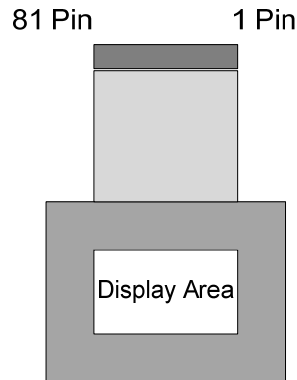

5.2 Pin description (LVDS input)

Pin No. (FPC Side)	Symbol	Type	Description	Equivalent circuit
1	VCATH	Power Supply	EL cathode power supply	
2	VCATH	Power Supply	EL cathode power supply	
3	VCCP_O	Power Supply	VCCP power supply	※8
4	VCCP_I	Power Supply	VCCP power supply	
5	VCCP_I	Power Supply	VCCP power supply	
6	VDD2	Power Supply	10V power supply	
7	VDD2	Power Supply	10V power supply	
8	VSS	Power Supply	GND	
9	VSS	Power Supply	GND	
10	VSS	Power Supply	GND	
11	VSS	Power Supply	GND	
12	VDD1	Power Supply	1.8V power supply	
13	VDD1	Power Supply	1.8V power supply	
14	XCS	Input	Serial communication Chip select	※1
15	XSCK	Input	Serial communication Serial clock	※1
16	SI	Input	Serial communication Data input	※1
17	SO	Output	Serial communication Data output	※2
18	PSCNT	Input	Power save communication enable Connect to GND	※1
19	XCLR	Input	System reset	※1
20	TEST	Output	Test pin (no connect)	※3
21	TEST	-	Test pin (connect to GND)	

Pin No. (FPC Side)	Symbol	Type	Description	Equivalent circuit
22	TEST	Input	Test pin (connect to GND)	※4
23	TEST	Input	Test pin (connect to GND)	※5
24	TEST	Input	Test pin (connect to GND)	※1
25	TEST	Input / Output	Test pin (connect to GND)	※4
26	TEST	Output	Test pin (no connect)	※1
27	VDD1IF	Power Supply	1.8V power supply for LVDS	
28	VSSIF	Power Supply	GND for LVDS	
29	TEST	Input	Test pin (connect to GND)	※6
30	TEST	Input	Test pin (connect to GND)	※6
31	LV1A	Input	LVDS clock	※6
32	LV1B	Input	LVDS clock	※6
33	LV2A	Input	LVDS data input	※6
34	LV2B	Input	LVDS data input	※6
35	LV3A	Input	LVDS data input	※6
36	LV3B	Input	LVDS data input	※6
37	LV4A	Input	LVDS data input	※6
38	LV4B	Input	LVDS data input	※6
39	LV5A	Input	LVDS data input	※6
40	LV5B	Input	LVDS data input	※6
41	VDD1IF	Power Supply	1.8V power supply for LVDS	
42	VSSIF	Power Supply	GND for LVDS	
43	TEST	Input	Test pin (connect to GND)	※6
44	TEST	Input	Test pin (connect to GND)	※6
45	VSSIF	Power Supply	GND for LVDS	
46	VDD1IF	Power Supply	1.8V power supply for LVDS	
47	LV9A	Input	LVDS data input	※6
48	LV9B	Input	LVDS data input	※6
49	LV8A	Input	LVDS data input	※6
50	LV8B	Input	LVDS data input	※6
51	LV7A	Input	LVDS data input	※6
52	LV7B	Input	LVDS data input	※6
53	LV6A	Input	LVDS data input	※6
54	LV6B	Input	LVDS data input	※6
55	LV10A	Input	LVDS clock	※6
56	LV10B	Input	LVDS clock	※6
57	TEST	Input	Test pin (connect to GND)	※6

Pin No. (FPC Side)	Symbol	Type	Description	Equivalent circuit
58	TEST	Input	Test pin (connect to GND)	※6
59	VSSIF	Power Supply	GND for LVDS	
60	VDD1IF	Power Supply	1.8V power supply for LVDS	
61	TEST	Output	Test pin (no connect)	※1
62	IFSW	Input	Interface select pin (connect to GND)	※1
63	VDD1	Power Supply	1.8V power supply	
64	VDD1	Power Supply	1.8V power supply	
65	VSS	Power Supply	GND	
66	VSS	Power Supply	GND	
67	TEST	Input	Test pin (connect to GND)	※7
68	VCAL	Output	Output of temperature sensing circuit	※8
69	R_IB	Input / Output	Bias current adjustment resistance connect pin	※8
70	VREF	Output	VREF voltage	※8
71	VG255	Output	Gamma top voltage	※8
72	VG0	Output	Gamma bottom voltage	※8
73	VOFS	Output	Vofs voltage	※8
74	VSS	Power Supply	GND	
75	VSS	Power Supply	GND	
76	VDD2	Power Supply	10V power supply	
77	VDD2	Power Supply	10V power supply	
78	VCCP_I	Power Supply	VCCP power supply	
79	VCCP_I	Power Supply	VCCP power supply	
80	VCATH	Power Supply	EL cathode power supply	
81	VCATH	Power Supply	EL cathode power supply	

5.3 Equivalent Circuits

※1

- 14:XCS
- 15:XSCK
- 16:SI
- 18:PSCNT
- 19:XCLR
- 24:CLK1
- 62:IFSW

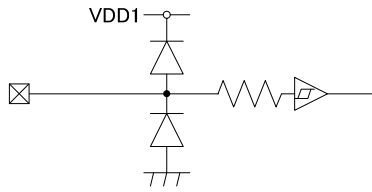

※2

- 17:SO

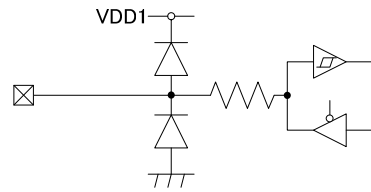

※3

- 20:TEST

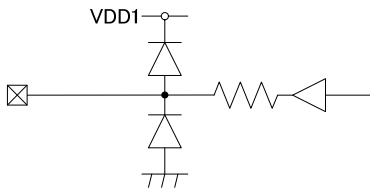

※4

- 22:XVD
- 25:TEST
- 26:TEST
- 61:TEST

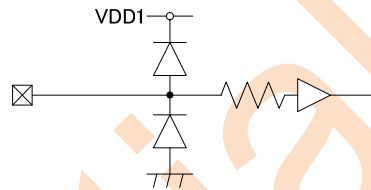

※5

- 23:TEST

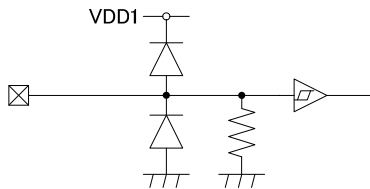

※6

- 29-40:data
- 43-44:CLKA CLKB
- 47-58:data

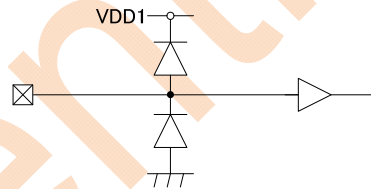

※7

- 67:TEST

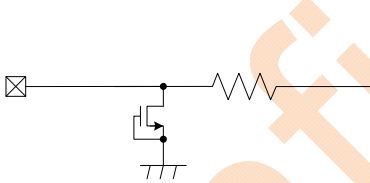

※8

- 3:VCCP_O
- 68:VCAL
- 69:RJB
- 70:VREF
- 71:VG255
- 72:VGO
- 73:VOFS

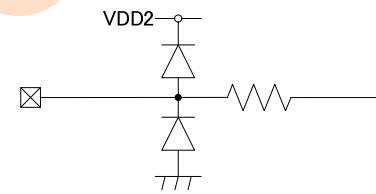

5.4 Peripheral Circuit Example

Regarding power supply capacitor connections, mount an approximately 2.2 μF to 10 μF capacitor for each power supply. Insufficient capacitance may affect the picture quality.

External capacitor characteristic :X5R or Class B

Notes

Regarding power supply connections, mount an appropriate capacitor as close to the connector as possible. Insufficient capacitance may affect the picture quality

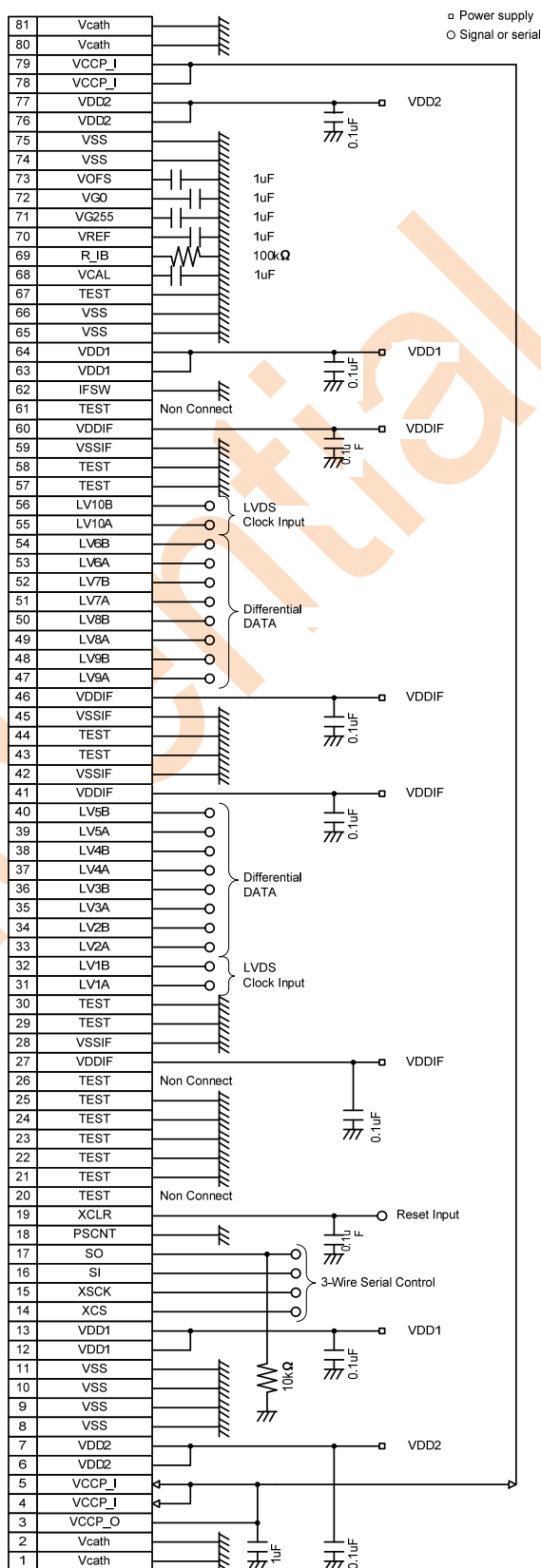

※Above circuit is just one of typical example for reference to drive the module. Sony does NOT take any liability if the circuit example causes any problem because the circuit is only for reference.

6. Absolute Maximum Ratings

Item	Symbol	Min.	Maximum Ratings	Unit
1.8V power supply	VDD1	-0.3	2.0	V
1.8V power supply (IF)	VDD1IF	-0.3	2.5	V
10 V power supply	VDD2	-0.3	12.0	V
EL cathode voltage	Vcath	-0.3	0.3	V
Logic input voltage ※	Vi	-0.3	VDD1+0.3	V
IF input voltage ※※	ViIF	-0.3	VDD1IF+0.3	V
Storage temperature	Tpnl	-30	+80	°C

※ Pin no. 14,15,16,18,19,22,23,24 & 62

※※ Pin no. 29 to 40,43,44 & 47 to 58

7. Recommended Operating Conditions

Item	Symbol	Min.	Typ.	Max.	Unit
1.8V power supply	VDD1	1.62	1.8	1.98	V
1.8V power supply (IF)	VDD1IF	1.62	1.8	1.98	V
10 V power supply	VDD2	9.7	10.0	10.3	V
EL cathode voltage	Vcath	-0.3	0	0.3	V
Operating temperature range	Tpnl	-20		70	°C

8. Electrical Characteristics

8.1. DC Characteristics

Item	Symbol	Conditions	Min.	Typ.	Max.	Unit
High-level input voltage	VIH		0.7VDD1		VDD1	V
Low-level input voltage	VIL		0		0.3VDD1	V
Logic High -level Output voltage	VOH		VDD1 - 0.5			V
Logic Low -level Output voltage	VOL				0.5	V

8.2. AC Characteristics

Item	Symbol	Conditions	Min.	Typ.	Max.	Unit
XSCK frequency	f_XSCK			0.8	2.5	MHz
XCS setup time	st_XCS		0.4			μs
XCS hold time	hd_XCS		0.2			μs
SI setup time	st_SI		0.2			μs
SI hold time	hd_SI		0.2			μs

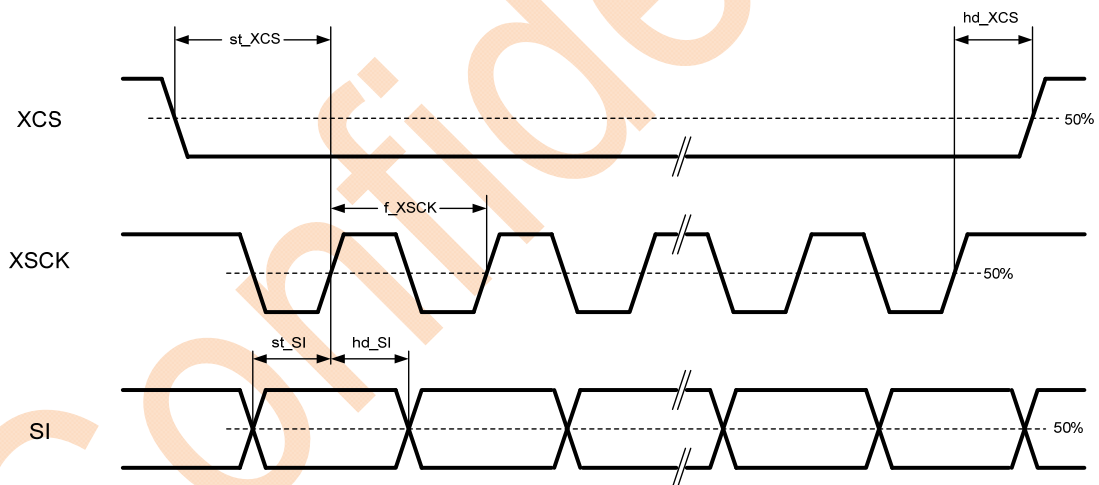

8.3. LVDS I/F Specifications

- ◆Resolution :Full-HD 1920x1080
- ◆Frame Rate :60Hz
- ◆Number of colors :24bit (16777K)
- ◆Number of pairs :Clk: 2pairs, Data:8pairs

8.4. DC Characteristics

Item	Symbol	Min.	Typ.	Max.	Unit
Voltage range (*)	Vi	890		1550	mV
Common Mode Voltage	Vic	1040		1400	mV
Each DATA-DATA and DATA-CLK Vic difference	Δ Vic			35	mV
Differential Input Voltage	Vid	130		300	mV
Each DATA-DATA and DATA-CLK Vid difference	Δ Vid			35	mV
Driver-receiver ground potential difference	Vgpd			50	mV

(*)Assumed driver output differential voltage =180mV

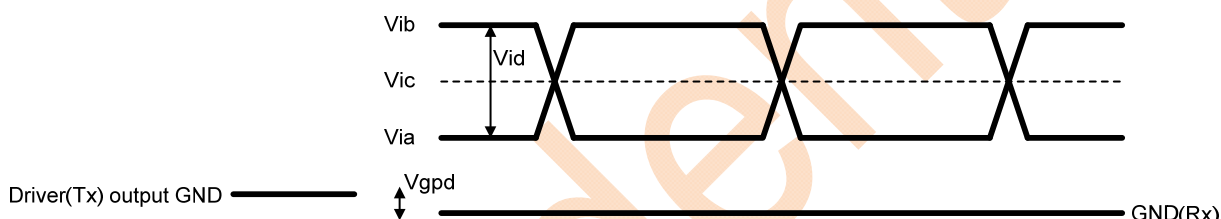

8.5. LVDS AC Characteristics

Item	Symbol	Min.	Typ.	Max.	Unit
Tx Timing Budget	tTOP	-250	0	250	psec
Tx tLVT	tLVT	300	500	600	psec
Odd and Even clock skew	OESKEW	0		500	psec

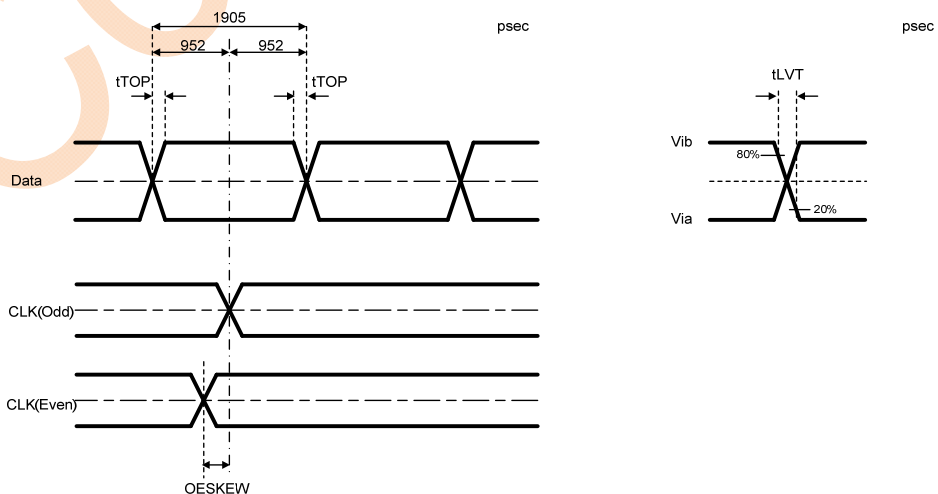

8.6 Power Consumption

Item	Symbol	Condition	Typ. (*)						Unit
			3000	1500	500	300	120	Standby	
VDD1 power consumption	PDD1	VDD1=1.8V VDD2=10V LVDS input T _{pnl} =40°C	35	35	35	35	35	0.5	mW
VDD1IF power consumption	PDD1IF		75	75	75	75	75	0	mW
VDD2 power consumption	PDD2		1170	710	400	340	290	0	mW
Total power consumption	PDDTTL		1280	820	510	450	400	0.5	mW

*: All white raster display, Clock frequency = 148.5MHz, Frame rate = 60Hz

Confidential

9. Power Supply Sequence

Power supply sequence shown in below should be followed to avoid panel breakdown caused by excessive current flow into the internal circuit.

9.1 Sequence Diagram

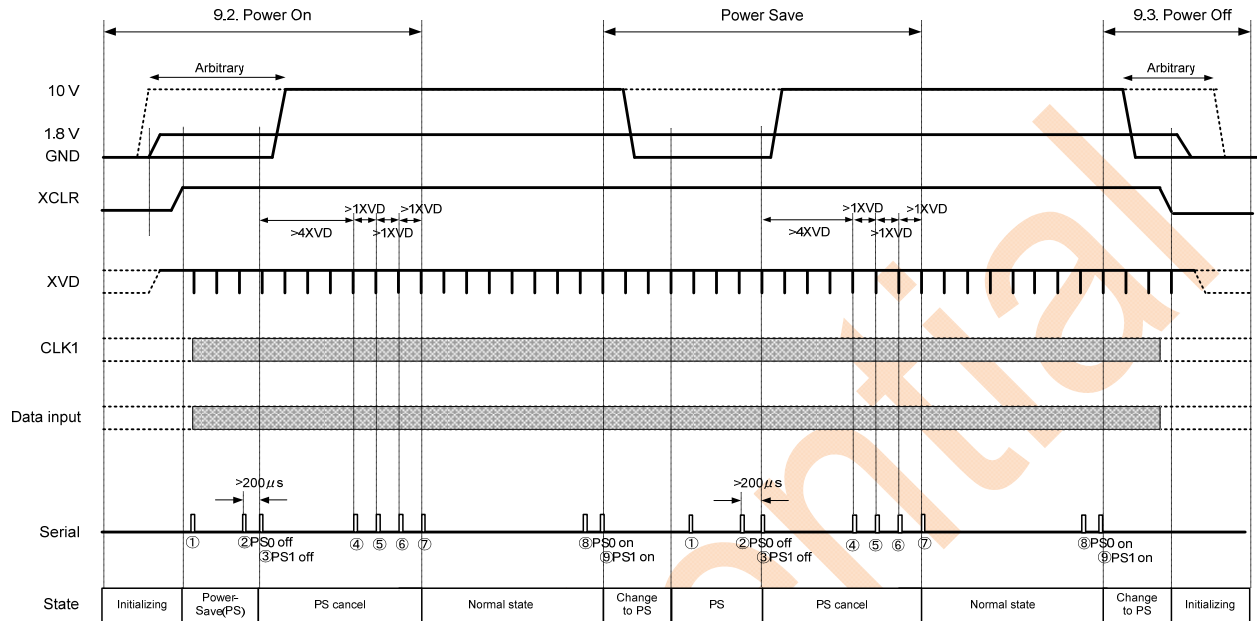

Data									
Address	Serial Setting①	Serial Setting②	Serial Setting③	Serial Setting④	Serial Setting⑤	Serial Setting⑥	Serial Setting⑦	Serial Setting⑧	Serial Setting⑨
0x00		0x0F						0x0E	
0x01			0x01						0x00
0x02	0x40								
0x03	0xA0						0x20		
0x04	0x5F			0x3F					
0x6D	0x04					0x00			
0x6F	0x03					0x00			
0x71	0x4E				0x46	0x00			
0x72	0x4E				0x46	0x00			

9.2. Power On Sequence

1. Set XCLR to low and turn on 1.8V power supply.
2. After completion of 1.8 V power supply rising, set XCLR to high, then the panel changes to the power-saving mode.
3. Perform the serial setting ①
4. Perform power-save 0 (PS0) off serial setting ②, then perform power-save 1 (PS1) off serial setting ③ at an interval of $> 200\mu s$.

5. After serial setting ③ completion, perform the serial setting ④ at an interval of “> 4XVD”.
6. After serial setting ④ completion, perform the serial setting ⑤ at an interval of “> 1XVD”.
7. After serial setting ⑤ completion, perform the serial setting ⑥ at an interval of “> 1XVD”.
8. After serial setting ⑥ completion, perform the serial setting ⑦ within V-blanking period just after 1V period from serial setting ⑥.

*Complete turning on of 10V power supply within “3 XVD” periods after power saving mode off setting ③, while the order of turning on of 1.8V and 10V power supply is not restricted.

9.3. Power Off Sequence

1. Perform PS0 on and PS1 on serial setting to enter power-saving mode.
2. After power-saving mode starts, set XCLR to low and turn off 1.8V and 10V power supplies.

*Turning off of 1.8V and 10V power supplies should be done after completion of setting XCLR to low, while the order of turning off of 1.8V and 10V power supply is not restricted.

10. Description of Function

10.1. Serial Communication

10.1.1. Register Map

	Addr.	DATA7	DATA6	DATA5	DATA4	DATA3	DATA2	DATA1	DATA0	Initial	
0	+0x00	RGB_YCB	YCB_DEC	*	*	DWN	RGT	MCLKPOL	PS0	0E	
1	+0x01	VCAL_MON	CALSEL[1:0]		YCB_P	*	*	*	PS1	00	
2	+0x02	*	*	*	ORBIT_H[4:0]					00	
3	+0x03	*	*	*	ORBIT_V[4:0]					00	
4	+0x04	*	*	*	*	*	*	*	*	1F	
5	+0x05	*	*	*	*	DITHERON	LUMINANCE[2:0]			00	
6	+0x06	*	*	*	*	*	*	*	*	00	
7	+0x07	*	*	*	*	*	*	*	*	00	
8	+0x08	*	*	*	*	*	OTPCALDAC_REGDIS	*	OTPDG_REGDIS	00	
9	+0x09	*	*	*	*	*	*	*	*	56	
A	+0x0A	*	*	*	*	*	*	*	*	00	
B	+0x0B	*	*	*	*	*	*	*	*	00	
C	+0x0C	*	*	*	*	*	*	*	*	00	
D	+0x0D	*	*	*	*	*	*	*	*	00	
E	+0x0E	*	*	*	*	*	*	*	*	00	
F	+0x0F	*	*	*	*	*	*	*	*	00	
10	+0x10	*	*	*	*	*	*	*	*	00	
11	+0x11	*	*	*	*	*	*	*	*	00	
12	+0x12	*	*	*	*	*	*	*	*	00	
13	+0x13	*	*	*	*	*	*	*	*	00	
14	+0x14	CONT[7:0]								00	
15	+0x15	CONT[8]	RCONT[6:0]								C0
16	+0x16	*	GCONT[6:0]								40
17	+0x17	*	BCONT[6:0]								40
18	+0x18	BRT[7:0]								80	
19	+0x19	*	RBRT[6:0]								40
1A	+0x1A	*	GBRT[6:0]								40
1B	+0x1B	*	BBRT[6:0]								40
1C	+0x1C	*	*	*	*	*	*	*	*	10	
1D	+0x1D	CALDAC[7:0]								80	
1E	+0x1E	*	*	*	*	*	*	*	*	40	
1F	+0x1F	*	*	*	*	*	*	*	*	10	
20	+0x20	H_ACT_U[7:0]								60	
21	+0x21	H_ACT_U[8]	V_ACT_D[10:8]			*	H_ACT_D[10:8]			44	
22	+0x22	H_ACT_D[7:0]								20	
23	+0x23	V_ACT_U[7:0]								29	
24	+0x24	V_ACT_D[7:0]								61	
25	+0x25	*	*	*	*	*	*	*	*	00	
26	+0x26	*	*	*	*	*	*	*	*	04	
27	+0x27	*	*	*	*	*	*	*	*	4C	
28	+0x28	*	DE_D[10:8]			*	DE_U[10:8]			40	
29	+0x29	DE_U[7:0]								58	
2A	+0x2A	DE_D[7:0]								28	
2B	+0x2B	*	*	*	*	*	*	*	*	04	
2C	+0x2C	*	*	*	*	*	*	*	*	65	
2D	+0x2D	*	WSST1_D[10:8]			*	WSST1_U[10:8]			00	
2E	+0x2E	WSST1_U[7:0]								18	
2F	+0x2F	WSST1_D[7:0]								19	
30	+0x30	*	WSST2_D[10:8]			*	WSST2_U[10:8]			44	
31	+0x31	WSST2_U[7:0]								0D	
32	+0x32	WSST2_D[7:0]								0E	

33	+0x33	*	*	*	*	*	*	*	*	80	
34	+0x34	*	*	*	*	*	*	*	*	00	
35	+0x35	*	*	*	*	*	*	*	*	24	
36	+0x36	WSEN1_U[7:0]								DD	
37	+0x37	*	*	*	*	*	*	*	WSEN1_U[8]	00	
38	+0x38	WSEN1_W[7:0]								01	
39	+0x39	*	*	*	*	*	WSEN2_U[10:8]			04	
3A	+0x3A	WSEN2_U[7:0]								35	
3B	+0x3B	WSEN2_W[7:0]								07	
3C	+0x3C	WSEN3_U[7:0]								5D	
3D	+0x3D	WSEN3_W[7:0]								0A	
3E	+0x3E	DSEN_U[7:0]								B6	
3F	+0x3F	*	*	*	DSEN_U[8]	*	DSEN_W[10:8]			03	
40	+0x40	DSEN_W[7:0]								8D	
41	+0x41	*	*	VCK_W[9:8]			*	*	VCK_U[9:8]	00	
42	+0x42	VCK_U[7:0]								01	
43	+0x43	VCK_W[7:0]								7B	
44	+0x44	*	*	*	*	*	*	SGSELREF_U[9:8]			00
45	+0x45	SIGSELREF_U[7:0]								17	
46	+0x46	SIGSELREF_W[7:0]								76	
47	+0x47	*	*	*	*	SIGSELOFS_U[3:0]				00	
48	+0x48	SIGSELOFS_W[7:0]								76	
49	+0x49	*	*	SIGSEL_W[9:8]			SIGSEL_U[3:0]			00	
4A	+0x4A	SIGSEL_W[7:0]								5A	
4B	+0x4B	*	*	*	*	*	*	SELREF_U[9:8]			00
4C	+0x4C	SELREF_U[7:0]								0A	
4D	+0x4D	SELREF_W[7:0]								5D	
4E	+0x4E	SELOFS_U[7:0]								0A	
4F	+0x4F	SELOFS_W[7:0]								5D	
50	+0x50	*	*	SEL_W[9:8]			*	*	SEL_U[9:8]	00	
51	+0x51	SEL_U[7:0]								0A	
52	+0x52	SEL_W[7:0]								41	
53	+0x53	*	*	*	*	*	*	*	*	00	
54	+0x54	*	*	*	*	*	*	*	*	51	
55	+0x55	*	*	*	*	*	*	*	*	0A	
56	+0x56	*	*	*	*	*	*	*	*	38	
57	+0x57	*	AZEN_D[10:8]				*	*	*	AZEN_U[8]	40
58	+0x58	AZEN_U[7:0]								62	
59	+0x59	AZEN_D[7:0]								2F	
5A	+0x5A	*	*	*	*	*	*	*	*	00	
5B	+0x5B	*	*	*	*	*	*	*	*	76	
5C	+0x5C	*	*	*	*	*	*	*	*	00	
5D	+0x5D	*	*	*	*	*	*	*	*	01	
5E	+0x5E	*	*	*	*	*	*	*	*	0B	
5F	+0x5F	*	*	*	*	*	*	*	*	00	
60	+0x60	*	*	*	*	*	*	*	*	01	
61	+0x61	*	*	*	*	*	*	*	*	A0	
62	+0x62	*	*	*	*	*	*	*	*	00	
63	+0x63	*	*	*	*	*	*	*	*	02	
64	+0x64	*	*	*	*	*	*	*	*	0F	
65	+0x65	*	*	*	*	*	*	*	*	00	
66	+0x66	*	*	*	*	*	*	*	*	00	
67	+0x67	*	*	*	*	*	*	*	*	00	
68	+0x68	*	*	*	*	*	*	*	*	00	
69	+0x69	*	*	*	*	*	*	*	*	00	
6A	+0x6A	*	*	*	*	*	*	*	*	00	
6B	+0x6B	*	*	*	*	*	*	*	*	00	
6C	+0x6C	*	*	*	*	*	*	*	*	00	

6D	+0x6D	120MODE	*	*	*	*	*	*	*	00
6E	+0x6E	*	*	*	*	*	*	*	*	E8
6F	+0x6F	*	*	*	*	*	*	*	*	00
70	+0x70	*	*	*	*	*	*	*	*	00
71	+0x71	*	*	*	*	*	*	*	*	00
72	+0x72	*	*	*	*	*	*	*	*	00
73	+0x73	*	*	*	*	*	*	*	*	00
74	+0x74	*	*	*	*	*	*	*	*	00
75	+0x75	*	*	*	*	*	*	*	*	00
76	+0x76	*	*	*	*	*	*	*	*	00
77	+0x77	*	*	*	*	*	*	*	*	00
78	+0x78	*	*	*	*	*	*	*	*	00
79	+0x79	*	*	*	*	*	*	*	*	00
7A	+0x7A	*	*	*	*	*	*	*	*	00
7B	+0x7B	*	*	*	*	*	*	*	*	00
7C	+0x7C	*	*	*	*	*	*	*	*	00
7D	+0x7D	*	*	*	*	*	*	*	*	30
7E	+0x7E	*	*	*	*	*	*	*	*	00
7F	+0x7F	*	*	*	*	*	*	*	*	00
80	+0x80	*	*	*	*	*	*	*	RD_ON	00
81	+0x81	RD_ADDR[7:0]								00

* Setting values should be submitted separately.

Confidential

10.1.2. Description of Register

Register	Bits	V sync	Function	Related Items
PS0	1		Power save mode 0: Power save on 1: Power save off	9.2 9.3
MCLKPOL	1		MCLK polarity 0: Negative 1: Positive	—
RGT	1		Selection of rightward / leftward scan	10.4
DWN	1		Selection of upward / down ward scan	10.4
YCB_DEC	1		Selection of YCbCr / YPbPr conversion	10.2
RGB_YCB	1		Selection of RGB / YCbCr (YPbPr) format	10.2
PS1	1		IF block output control 0: off (PS1 on) 1: output (PS1 off)	9.2 9.2
YCB_P	1		Selection of YCbCr (YPbPr) input pattern	10.2
CALSEL	2		VCAL output selection	10.5
VCAL_MON	1		Temperature sensing circuit monitoring on / off	10.5
ORBIT_H	5	○	Horizontal orbit adjustment	10.10.1
ORBIT_V	5	○	Vertical orbit adjustment	10.10.2
LUMINANCE	3		Luminance and white chromaticity preset mode selection	10.6
DITHERON	1		Dithering On/Off	10.9
OTPDG_REGDIS	1		White chromaticity preset mode on / off	10.6
OTPCALDAC_REGDIS	1		Luminance preset mode on / off	10.6
CONT	9		Contrast adjustment	10.8.1
RCONT	7		R sub-contrast adjustment	10.8.1
GCONT	7		G sub-contrast adjustment	10.8.1
BCONT	7		B sub-contrast adjustment	10.8.1
BRT	8		Brightness adjustment	10.8.2
RBRT	7		R sub-brightness adjustment	10.8.2
GBRT	7		G sub-brightness adjustment	10.8.2
BBRT	7		B sub-brightness adjustment	10.8.2
CALDAC	8		Manual luminance adjustment	10.7
H_ACT_U	9		Timing setting register (setting value separately submitted)	10.3
H_ACT_D	11		Timing setting register (setting value separately submitted)	10.3
V_ACT_U	8		Timing setting register (setting value separately submitted)	10.3
V_ACT_D	11		Timing setting register (setting value separately submitted)	10.3
DE_U	11		Timing setting register (setting value separately submitted)	10.3
DE_D	11		Timing setting register (setting value separately submitted)	10.3
WSST1_U	11		Timing setting register (setting value separately submitted)	10.3
WSST1_D	11		Timing setting register (setting value separately submitted)	10.3
WSST2_U	11		Timing setting register (setting value separately submitted)	10.3

Register	Bits	V sync	Function	Related Items
WSST2_D	11		Timing setting register (setting value separately submitted)	10.3
WSEN1_U	9		Timing setting register (setting value separately submitted)	10.3
WSEN1_W	8		Timing setting register (setting value separately submitted)	10.3
WSEN2_U	11		Timing setting register (setting value separately submitted)	10.3
WSEN2_W	8		Timing setting register (setting value separately submitted)	10.3
WSEN3_U	8		Timing setting register (setting value separately submitted)	10.3
WSEN3_W	8		Timing setting register (setting value separately submitted)	10.3
DSEN_U	9		Timing setting register (setting value separately submitted)	10.3
DSEN_W	11		Timing setting register (setting value separately submitted)	10.3
VCK_U	10		Timing setting register (setting value separately submitted)	10.3
VCK_W	10		Timing setting register (setting value separately submitted)	10.3
SIGSELREF_U	10		Timing setting register (setting value separately submitted)	10.3
SIGSELREF_W	8		Timing setting register (setting value separately submitted)	10.3
SIGSELOFS_U	4		Timing setting register (setting value separately submitted)	10.3
SIGSELOFS_W	8		Timing setting register (setting value separately submitted)	10.3
SIGSEL_U	4		Timing setting register (setting value separately submitted)	10.3
SIGSEL_W	10		Timing setting register (setting value separately submitted)	10.3
SELREF_U	10		Timing setting register (setting value separately submitted)	10.3
SELREF_W	8		Timing setting register (setting value separately submitted)	10.3
SELOFS_U	8		Timing setting register (setting value separately submitted)	10.3
SELOFS_W	8		Timing setting register (setting value separately submitted)	10.3
SEL_U	10		Timing setting register (setting value separately submitted)	10.3
SEL_W	10		Timing setting register (setting value separately submitted)	10.3
AZEN_U	9		Timing setting register (setting value separately submitted)	10.3
AZEN_D	11		Timing setting register (setting value separately submitted)	10.3
RD_ON	1		Register read on / off	10.1.4
RD_ADDR	8		Register read address setting	10.1.4

10.1.3. Serial I/F Write Access

Serial communication of normal / burst transfer, LSB first is supported for write operation.

Input the address of the objective register from SI pin (#16), then input the data to the address.

The timing of write access is shown below.

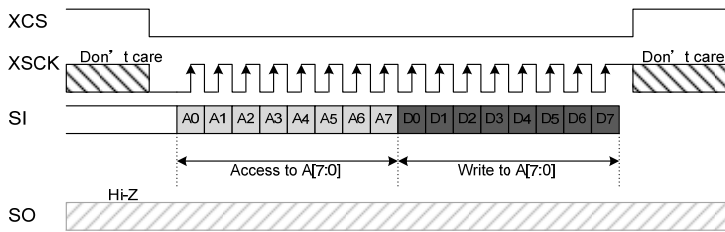

Write Access Normal Transfer (LSB First)

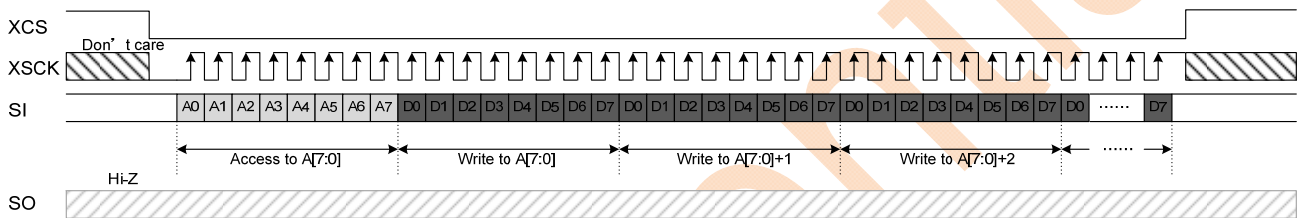

Write Access Burst Transfer (LSB First)

10.1.4 Serial I/F Read Access

Serial communication of normal / burst transfer, LSB first is supported for read operation.

◆Register Settings

Address	Register name	Bits	Function
0x80	RD_ON	1	Register read on / off 0: Off (default) 1: On
0x81	RD_ADDR	8	Register read address setting

Set RD_ON to 1, and then perform 2 times serial communication.

1st: Write the address of the objective register to RD_ADDR.

2nd: Read the data of the objective register from SO pin (#17) after accessing to the RD_ADDR.

The timing of read access is shown below.

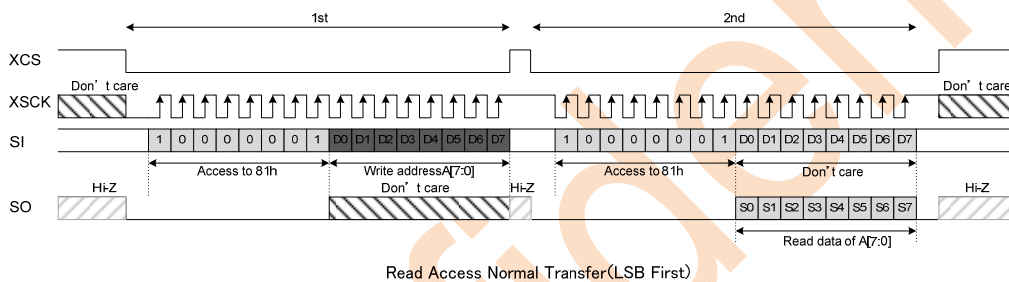

Read Access Normal Transfer (LSB First)

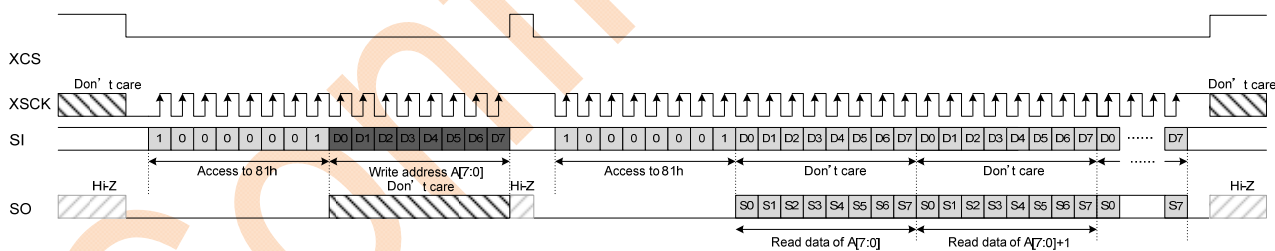

Read Access Burst Transfer (LSB First)

10.2. Video Signal Transfer Format

Set the registers appropriately for the video signal transfer format according to the table below.

◆Register Settings

Address	Register name	Bits	Function
0x00	RGB_YCB	1	Selection of RGB / YCbCr (YPbPr) format 0: RGB (default) 1: YCbCr and YPbPr
0x00	YCB_DEC	1	Selection of YCbCr / YPbPr conversion 0: YCbCr (BT. 601) (default) 1: YPbPr (BT. 709)
0x01	YCB_P	1	Selection of YCbCr (YPbPr) input pattern 0: Cb and Pb first (default) 1: Cr and Pr first

◆Register settings for each video signal transfer formats when YCB_DEC=0.

*Cb and Cr are replaced by Pb and Pr respectively when YCB_DEC=1.

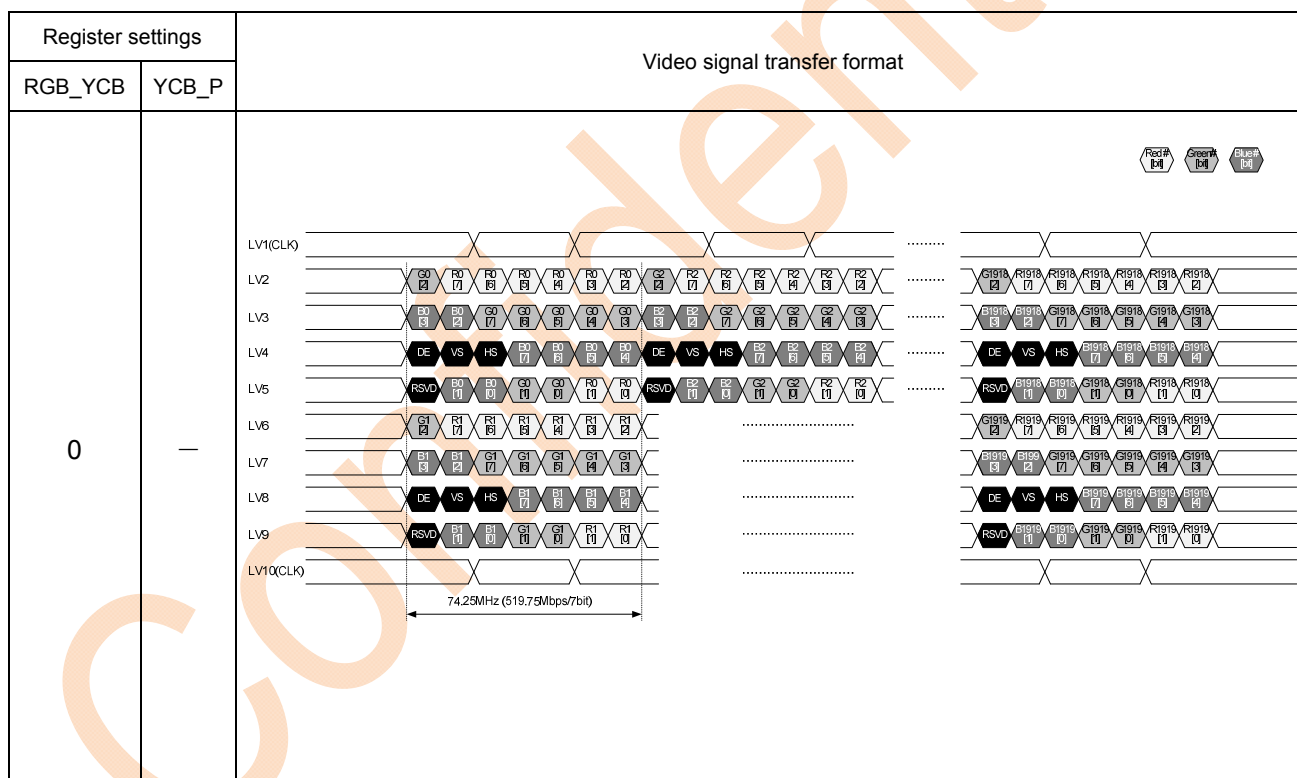

10.3. Input Signal Data Format

Set the panel timing registers appropriately for the input signal data format.

◆Register Settings

Address	Register name	Bits	Function
0x20 0x59	H_ACT_U AZEN_D		Timing setting registers. Should be set appropriately for the input signal data format. Setting values are separately presented.

◆Panel Display Modes and Input Supported Formats

Panel Display Mode		①Full-HD 59.94Hz / 60Hz Frame Rate	②Full-HD 50Hz Frame Rate	③Full-HD 47.952Hz / 48Hz Frame Rate
		1920(H) X 1080(V)	1920(H) X 1080(V)	1920(H) X 1080(V)
Input Supported Format				
Active	H	1920	1920	1920
	V	1080	1080	1080
Total	H	2200	2640	2750
	V	1125	1125	1125
FP	H	88	528	638
	V	4	4	4
SYNC	H	44	44	44
	V	5	5	5
BP	H	148	148	148
	V	36	36	36
BP+SYNC	H	192	192	192
	V	41	41	41
fv	Hz	59.95 / 60	50	47.952 / 48
Th	μs	14.830 / 14.815	17.778	18.537 / 18.519
Clock	MHz	148.35 / 148.5	148.5	148.35 / 148.5

10.4. Up/down and/or Right/left Inversion Function

Up/down and right/left inverse display of the panel are set by the registers RGT and DWN, respectively.

◆ Register settings

Address	Register	Bits	Setting Value
0x00	RGT	1	Selection of rightward / leftward scan 0: Leftward scan 1: Rightward scan (Default)
0x00	DWN	1	Selection of upward / downward scan 0: Upward scan 1: Downward scan (Default)

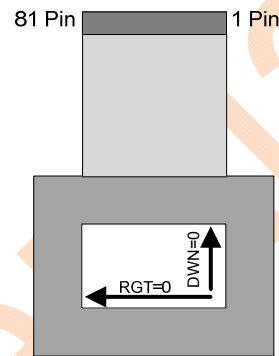
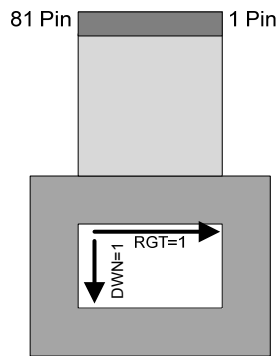

Confidential

10.5. Luminance Temperature Compensation Function

In general, luminance of OLED depends on display panel temperature as show in below. This module integrates luminance compensation function against panel temperature variation. This function allows to sustain relatively constant luminance even if panel temperature changing as shown in below.

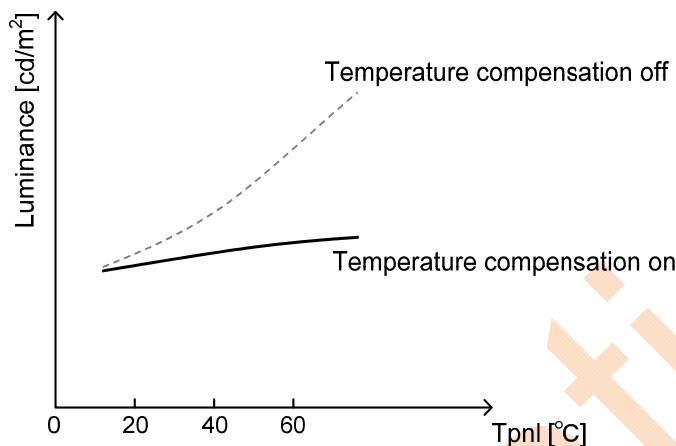

◆Register Settings

Address	Register name	Bits	Function
0x01	VCAL_MON	1	Display on/off when temperature sensor monitoring 0: on (Default) 1: off
0x01	CALSEL[1:0]	2	VCAL output selection 00: (default) 01: V1 output 10: V2 output

◆Method of Checking the Panel Temperature

The temperature sensor voltage can be received from VCAL pin (#92).

Setting the register CALSEL as noted in above, and read the “V1” and “V2” outputs. Actual panel temperature can be calculated by subtracting V1 from V2, refer figure in below

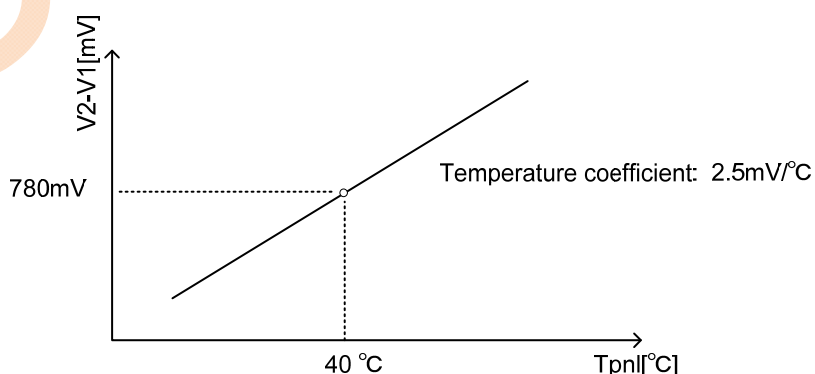

10.6. Luminance and White Balance Preset Mode

This product has four kinds of luminance preset mode. The three modes are set with white coordination as well. By selecting the mode according to the register "LUMINNACE", the luminance and the white chromaticity are adjusted to preset values as shown in below table.

◆Register Settings

Address	Register name	Number of bits	Function
0x08	OTPCALDAC_REGDIS	1	Luminance adjustment 0: Preset mode valid 1: Preset mode invalid (CALDAC adjustment)
0x08	OTPDG_REGDIS	1	White chromaticity adjustment 0: Preset mode valid 1: Preset mode invalid (CONT/BRT adjustment)
0x05	LUMINANCE[2:0]	3	Luminance and white chromaticity preset mode selection 1: 120cd/m ² , (0.313,0.350) 2: 300cd/m ² , (0.313,0.329) 0: 500cd/m ² , (0.313,0.329) 3: 1500cd/m ² , (0.310,0.310) 4: 3000cd/m ² , (0.310,0.310)

10.7. Luminance adjustment function

Manual luminance adjustment is performed by CALDAC register.

This function is valid when OTPCALDAC_REGDIS=1.

◆Register settings

Address	Register name	Bits	Function
0x08	OTPCALDAC_REGDIS	1	Luminance adjustment 0: Preset mode valid 1: Preset mode invalid (CALDAC adjustment)
0x1D	CALDAC[7:0]	8	Luminance adjustment setting value: 1 to 255 (in decimal notation) Default :128

Confidential

10.8. White Balance Adjustment Function

10.8.1. Contrast / Sub Contrast

White balance can be adjusted by two ways. One is to independently define of Red, Green, Blue luminance. Another is to simultaneously define them at once. Available to execute both ways at once, please refer example 2 in below. This function can be valid when “OTPDG_REGEN”=1.

◆ Register Settings

Address	Register name	Number of bits	Function
0x08	OTPDG_REGDIS	1	White chromaticity adjustment 0: Preset mode valid 1: Preset mode invalid (CONT and R/G/BCONT adjustment)
0x14, 0x15	CONT	9	To RGB input signal, $\times 0 \dots \times 1$ (Default) $\dots \times 1.99$
0x15	RCONT	7	Sets R relative to CONT to $\times 0.75 \dots \times 1$ (Default) $\dots \times 1.24$
0x16	GCONT	7	Sets G relative to CONT to $\times 0.75 \dots \times 1$ (Default) $\dots \times 1.24$
0x17	BCONT	7	Sets B relative to CONT to $\times 0.75 \dots \times 1$ (Default) $\dots \times 1.24$

◆ Contrast Adjustment (RGB Simultaneous Adjustment)

R, G and B output signal are adjusted simultaneously corresponding to the input signal using the register “CONT”. Setting value is 0 to 511 (decimal notation). Output gray level can be adjusted based on table in below.

CONT setting value	0	...	128	...	256 (Default)	...	384	...	511
Gain (to input)	$\times 0$...	$\times 0.5$...	$\times 1$...	$\times 1.5$...	$\times 1.99$

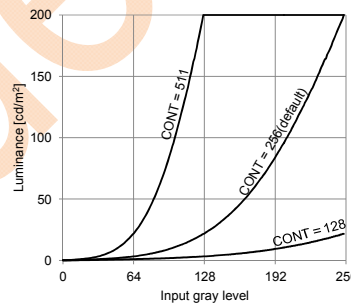
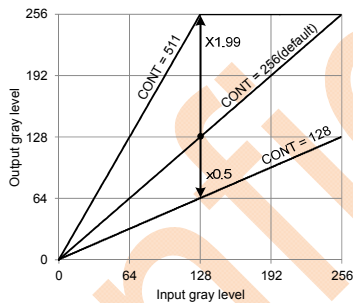

◆ Sub Contrast Adjustment (RGB independent adjustment)

R, G and B output signal are adjusted separately using RCONT, GCONT and BCONT registers respectively, besides the register “CONT”. The R, G and B output signal depends on both “RCONT, GCONT, BCONT” and “CONT”, as shown in examples in below. Gain for output and input is determined with multiple of “RCONT or GCONT or BCONT” and “CONT”. The “RCONT, GCONT, BCONT” setting range is 0 to 255 (decimal notation).

R/G/BCONT setting value	0	...	32	...	64 (Default)	...	96	...	127
Gain (to CONT)	$\times 0.75$...	$\times 0.875$...	$\times 1$...	$\times 1.125$...	$\times 1.24$

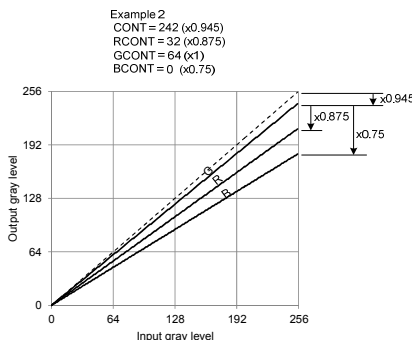
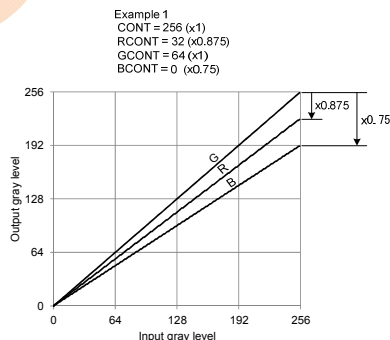

10.8.2. Bright/Sub Bright

There are two ways to adjust brightness. One is RGB simultaneous adjustment. Another is R, G and B independent brightness adjustment. Both ways can be applicable at once. This function is valid when “OTPDG_REGEN”=1.

◆Register Settings

Address	Register name	Number of bits	Function
0x08	OTPDG_REGDIS	1	White chromaticity adjustment 0: Preset mode valid 1: Preset mode invalid (BRT and R/G/BBRT adjustment)
0x18	BRT	8	To RGB input signal, -64 ... 0 (Default) ... +63 gradations
0x19	RBRT	7	Sets R relative to BRT to-32 ... 0 (Default) ... +31 gradations
0x1A	GBRT	7	Sets G relative to BRT to-32 ... 0 (Default) ... +31 gradations
0x1B	BBRT	7	Sets B relative to BRT to-32 ... 0 (Default) ... +31 gradations

◆Brightness Adjustment (RGB simultaneous Adjustment)

R, G and B of input signal can be adjusted simultaneously using register BRT. The setting value is 0 to 255 (decimal notation).

BRT setting value	0	...	64	...	128(Default)	...	192	...	255
Output gradations(to input)	-64	...	-32	...	0	...	+32	...	+63

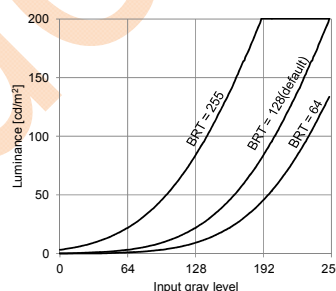
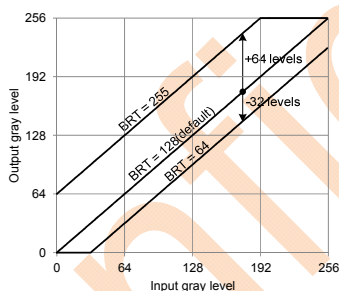

◆Sub Brightness Adjustment (RGB independent adjustment)

R, G and B output signal are adjusted separately using registers “RBRT, GBRT and BBRT” respectively, besides the register “BRT”. The R, G and B output signal depends on both “RBRT, GBRT, BBRT” and “BRT”, as shown in example in below. Offset between output and input is determined with sum of “RBRT or GBRT or BBRT” and “BRT”. The “RBRT, GBRT, BBRT” setting range is 0 to 255 (decimal notation).

R/G/BBRT setting value	0	...	32	...	64 (Default)	...	96	...	127
Output gradations (to BRT)	-32	...	-16	...	0	...	+16	...	+31

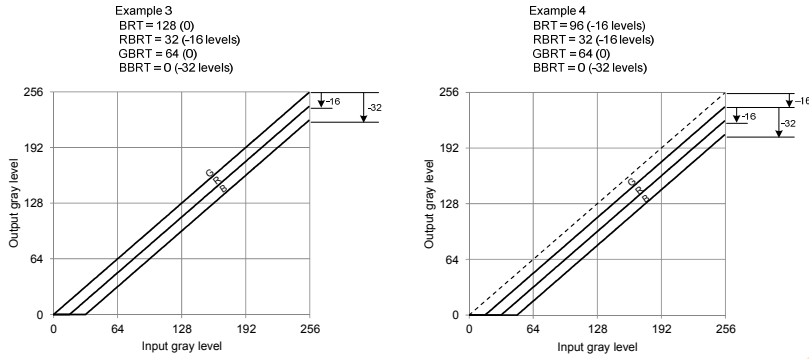

10.9. Dithering Function

This function expresses quasi-gradations between original gradations based on FRC (Frame Rate Control) technology. This function can compensate the loss of the number of gray level due to gray level sacrifice for contrast and brightness adjustment. In terms of the gray level sacrifice, please refer “10.8 Luminance adjustment function” and “10.9 White balance adjustment function”.

◆Register Settings

Address	Register name	Bits	Function
0x05	DITHERON	1	Dithering processing 0: Off 1: On

10.9.1. FRC (Frame Rate Control)

This function based on FRC technology. FRC can create quasi-gray levels between tangible gray levels based on time-resolution operation. Human eyes can percept brightness as average of time-wise in case displaying different brightness image under enough fast frame rate, as shown in below figure. The figure in below is case of 2bit FRC. When two gray levels are switching alternately in high-speed, human eyes can effectively percept average brightness of those two brightness levels as quasi-gray level. The quasi-gray level can be added besides original colors by changing data in 4-frame cycle making use of this property (2 bit FRC).

Quasi-gray level creation of 2bit FRC is shown in below, with assumption of one pixel.

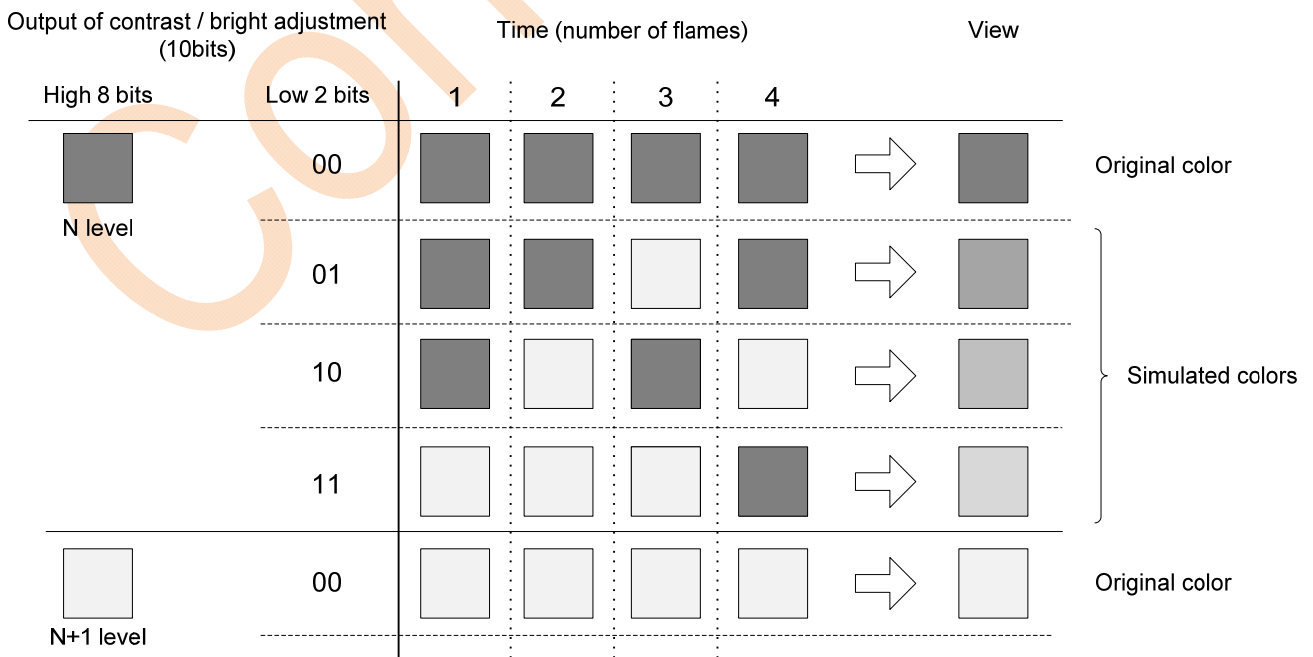

10.10. Orbit Function

Start position of data image can be changed. This enables reducing of unwanted noticeability of local luminance drop.

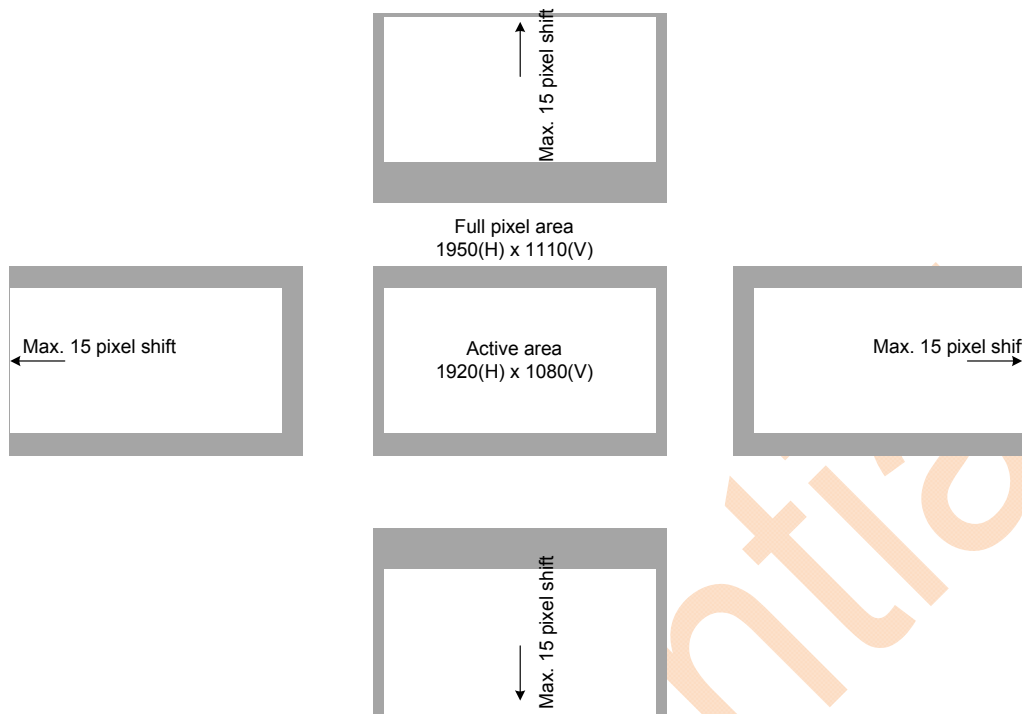

◆Register Settings

Address	Register name	Bits	Function
0x02	ORBIT_H[4:0]	5	Horizontal orbit adjustment -15 to 0 to +15, Default: 0
0x03	ORBIT_V[4:0]	5	Vertical orbit adjustment -15 to 0 to +15, Default: 0

10.1. Horizontal Display Position Shift

The horizontal display start position can be changed by the register ORBIT_H. The variable range is ± 15 pixels.

ORBIT_H setting value	-15	...	-1	0 (Default)	1	...	15
Number of pixels shifted	Leftward 15-pixel	...	Leftward 1-pixel	Center	Rightward 1-pixel	...	Rightward 15-pixel

10.2. Vertical Display Position Shift

The vertical display start position can be changed by the register ORBIT_V. The variable range is ± 15 pixels.

ORBIT_V setting value	-15	...	-1	0 (Default)	1	...	15
Number of pixels shifted	Upward 15-pixels	...	Upward 1-pixel	Center	Downward 1-pixel	...	Downward 15-pixel

11. Pixel Alignment

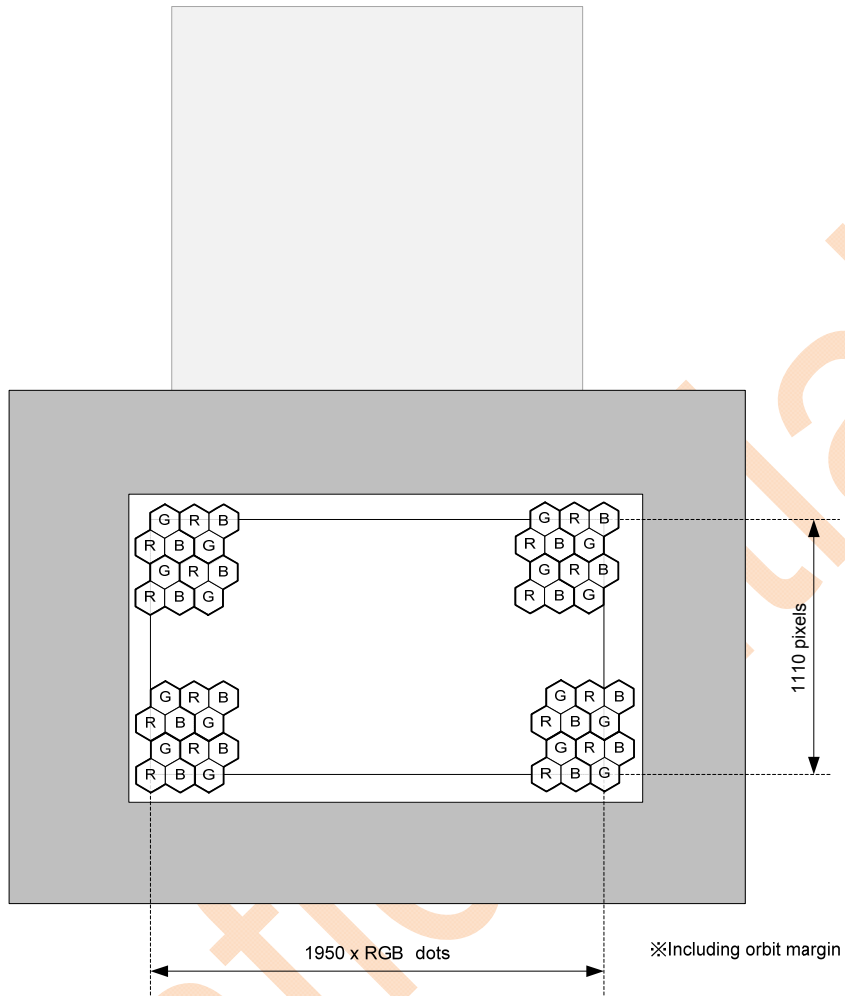

12. Optical Characteristics

12.1. Optical Characteristics

Item	Symbol	Min.	Typ.	Max.	Unit	
Luminance	Mode 1	L1	102	120	138	Cd/m ²
	Mode 2	L2	255	300	345	Cd/m ²
	Mode 0	L0	425	500	575	Cd/m ²
	Mode 3	L3	1275	1500	1725	Cd/m ²
	Mode 4	L4	2400	3000	3600	Cd/m ²
White chromaticity	Mode 1	W1x	0.298	0.313	0.328	CIE
		W1y	0.335	0.350	0.365	CIE
	Mode 2	W2x	0.301	0.313	0.325	CIE
		W2y	0.317	0.329	0.341	CIE
	Mode 0	W0x	0.301	0.313	0.325	CIE
		W0y	0.317	0.329	0.341	CIE
	Mode 3	W3x	0.298	0.310	0.322	CIE
		W3y	0.298	0.310	0.322	CIE
	Mode 4	W4x	0.295	0.310	0.325	CIE
		W4y	0.295	0.310	0.325	CIE
Monochrome chromaticity	R	Rx	0.630	0.650	0.670	CIE
		Ry	0.310	0.330	0.350	CIE
	G	Gx	0.250	0.270	0.290	CIE
		Gy	0.590	0.610	0.630	CIE
	B	Bx	0.130	0.150	0.170	CIE
		By	0.050	0.070	0.090	CIE
Contrast	CR	10,000	—	—		

12.2. Measurement System - Measurement Method

Measurement temperature: T_{pnl} = 40°C

Measurement point: One point on the screen center

Register setting: OTPCALDAC_REGDIS = 0、OTPDG_REGDIS = 0

Item		Pattern / Gray level		Register setting	Method
Luminance / White chromaticity	L1,W1x,W1y	White raster	R=255 G=255 B=255	LUMINANCE = 1	Measured by system A
	L2,W2x,W2y			LUMINANCE = 2	
	L0,W0x,W0y			LUMINANCE = 0	
	L3,W3x,W3y			LUMINANCE = 3	
	L4,W4x,W4y			LUMINANCE = 4	
Monochrome chromaticity	Rx,Ry	Red raster	R=255	Measured by system A	
	Gx,Gy	Green raster	G=255		
	Bx,By	Blue raster	B=255		
Contrast	CR	White & black raster	White: R=255 G=255 B=255 Black: R=0 G=0 B=0	LUMINANCE = 0	Measured by system A Contrast = white / black

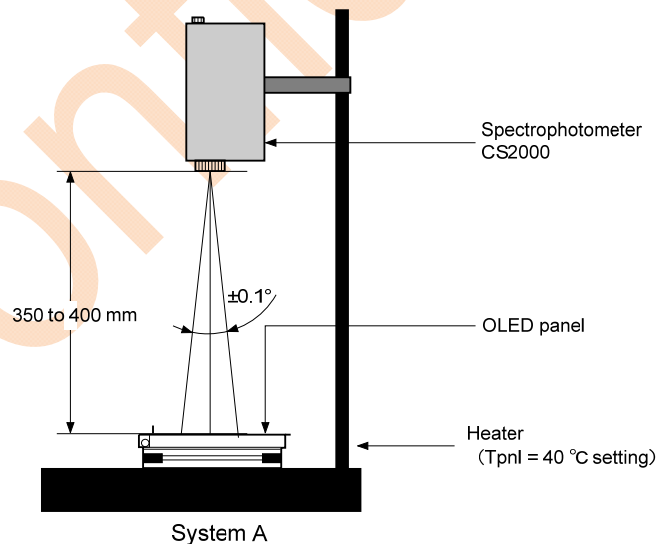

13. Picture Quality Specification

13.1. Dot and Pixel defect specification

Dot and Pixel defect specification is summarized in below. Definition of each defect is listed in following section.

	Inspection condition			Maximum acceptable number of defect			Minimum acceptable distance between defects	Reference
	Luminance 100%	Defect size	Criteria of Luminance Level	Zone A	Zone B	Total		
Bright Dot	Green Raster Red Raster Blue Raster (White 200cd/m2)	1 dot	Green : $L \geq 20\%$ Red : $L \geq 25\%$ Blue : $L \geq 80\%$	0	0	0	N/A	13.1.1
		1 dot	Green : $20\% > L \geq 11\%$ Red : $25\% > L \geq 11\%$ Blue : $80\% > L \geq 50\%$	0	2	2	“Horizontal 2 pixels” or “Vertical 2 pixels”	13.1.1
		1 dot	Green : $11\% > L$ Red : $11\% > L$ Blue : $50\% > L$	Ignored	Ignored	Ignored	N/A	13.1.1
Too-Bright Dot	White raster 200cd/m2	1 dot	Green : $L \geq 200\%$ Red : $L \geq 200\%$ Blue : $L \geq 300\%$	0	0	0	N/A	13.1.2
		1 dot	Green : $200\% > L$ Red : $200\% > L$ Blue : $300\% > L$	Ignored	Ignored	Ignored	N/A	13.1.2
Dim Pixel	White raster 200cd/m2	1 pixel	White : $10\% \geq L$	2	5	7	“Horizontal 2 pixels” or “Vertical 2 pixels”	13.1.3
		1 pixel	White : $L > 10\%$	Ignored	Ignored	Ignored	N/A	13.1.3

13.1.1 Definition of Bright dot defect

Suspected bright dot defect is inspected on Black raster display. Criteria to judge as defect or not should be comparison with Luminance level on Red or Green or Blue raster display, according to which dot is suspected. 1 Dot is unit of the Bright dot defect. Please refer definition for Dot and Pixel. Minimum acceptable distance between defects is defined as following.

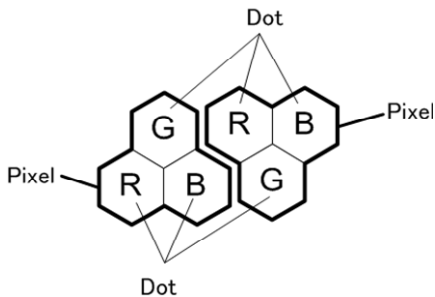

Definition of Pixel and Dot

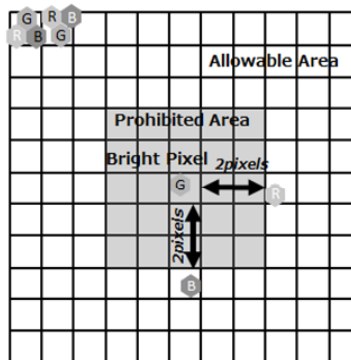

Minimum acceptable distance between defects

13.1.2 Definition of too-bright dot defect

Suspected too-bright dot defect is too-much brighter dot other than normal luminance. Criteria to judge as defect or not should be comparison with Luminance level on Red or Green or Blue raster display, according to which dot is suspected. Minimum acceptable distance between defects is same as that of bright dot defect.

13.1.3 Definition of Dim pixel defect

Suspected dim pixel is inspected White raster display. Criteria to judge as defect or not should be comparison with Luminance level on White raster. 1 pixel consists of 3 Dots. 1 Pixel is unit of the Dim pixel defect. And, minimum acceptable distance between defects is defined as following.

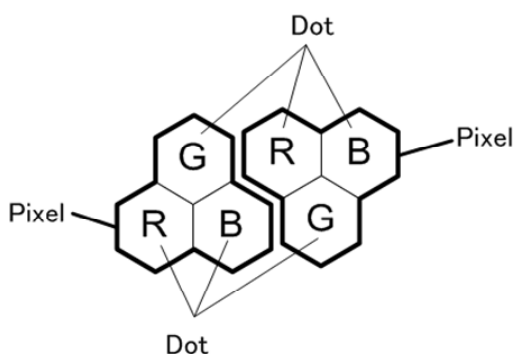

Definition of Pixel and Dot

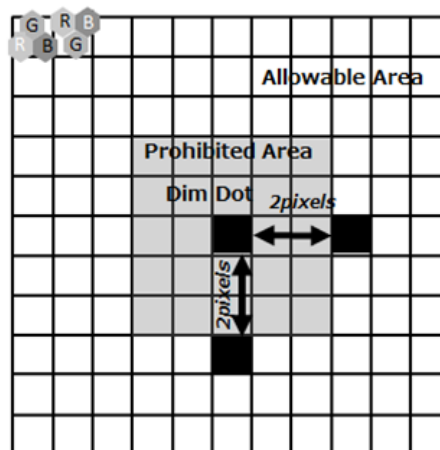

Minimum acceptable distance between defects

13.1.4 Definition of Zone A and B

Zone A and Zone B are defined as shown in below.

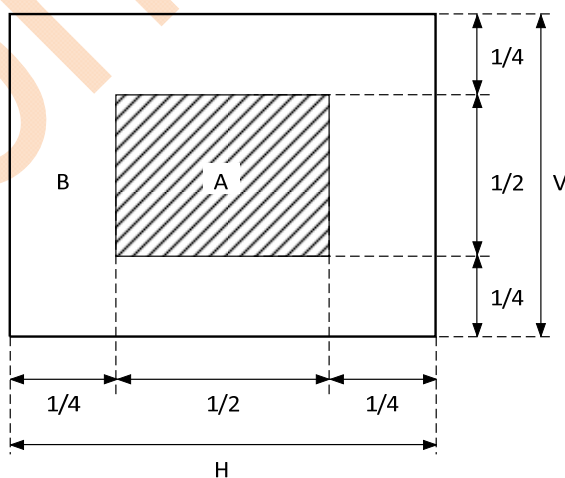

14. Line defect specification

Line defect specification and definition is summarized in below.

Item		Definition as defect	Maximum acceptable number of defect
Line defect	Bright line defect	Bright line consists of continuous 2 dots or more	0
	Dim line defect	Dim line consists of continuous 2 pixels or more	0

15. Uniformity Specification

Uniformity specification is unevenness display due to not dot or pixel defects but others.

(Tpn1 = 40 °C)

Item	Definition	Specification
Vertical uneven line	Dark uneven vertical line of 1 dot width on R or G, B raster.	There should be no abnormality that impairs practical usage. Separated discussions shall be held if needed.
Horizontal uneven line	Horizontal uneven line can be detected ranging from White raster to brighter gray raster.	
Dark stain	Dark strain can be detected at darker gray raster.	
Bright stain	Bright strain can be detected ranging from White raster to brighter gray raster.	
Uneven lines like string	Uneven lines like string can be detected ranging from White raster to brighter gray raster.	

16. Appearance Specification

Appearance specification is detected at power off because of physical related not electrical related defect.

Item	Definition	Specification
Abnormality on panel surface	For example, unevenness in Active Area. Chipping and scratching on other than Active Area, etc.	There shall be no hindrance to actual use. Separated discussions shall be held if needed. (Ignore abnormalities that cannot be detected in the picture quality inspection.)

17. Environmental Test

Item		Specification	Criteria
Storage test	High temperature	85 °C 1000 hours	There should be no remarkable deterioration in appearance and performance after the test.
	High temperature and high humidity	60 °C 90 % 1000 hours	
	Low temperature	-30 °C 1000 hours	
	Temperature cycle	-30 to 85 °C, 100 cycles (retention time is 30min.)	
Operation test	High temperature	70 °C 500 hours	There should be no remarkable abnormality that impairs use in display appearance and panel appearance.
	High temperature and high humidity	40 °C 95 % 500 hours	
	Low temperature	-10 °C 500 hours	
Strength test	Static charge	JEITA ED-4701/302 (HBM · CDM)	There should be no remarkable abnormality that impairs use in display appearance and panel appearance.
	Vibration	20 min. in X, Y, Z direction, 5 to 50 Hz (random wave vibration)	
	Shock	980m/s ² 6ms ±X, ±Y, ±Z (each 3 times)	

18. Module Outline

(Unit : mm)

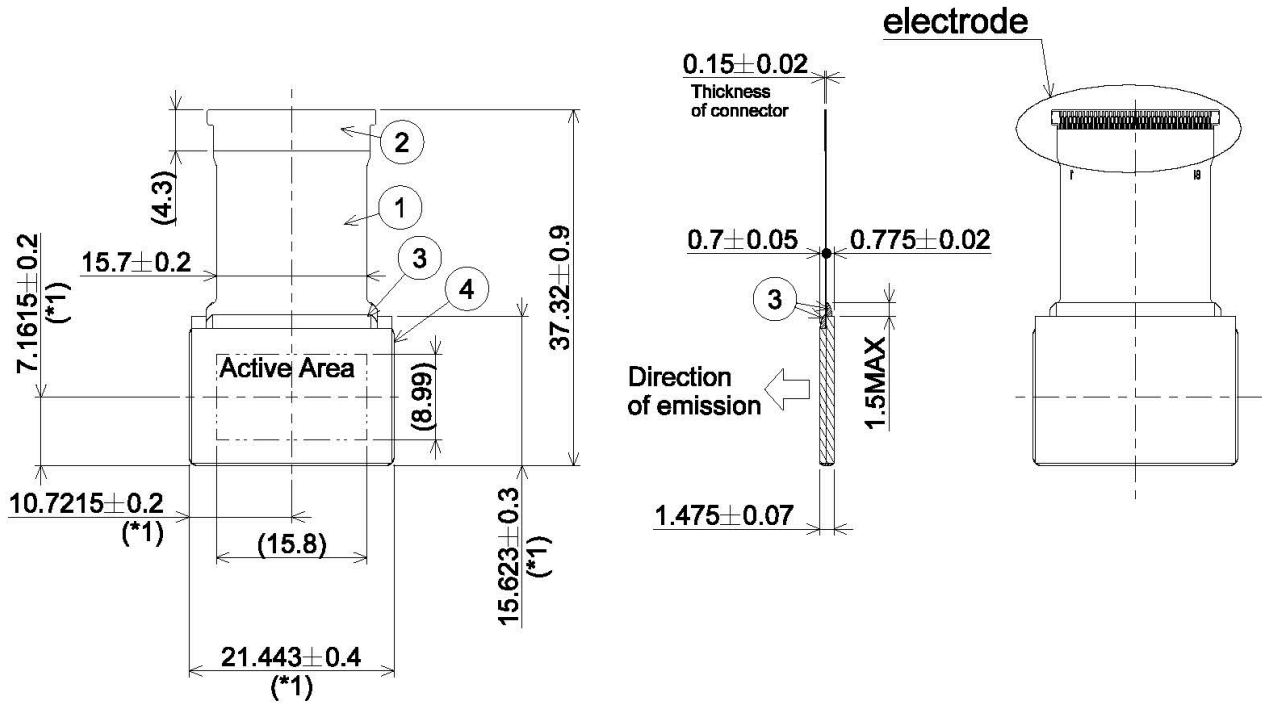

*1: including End-face coating

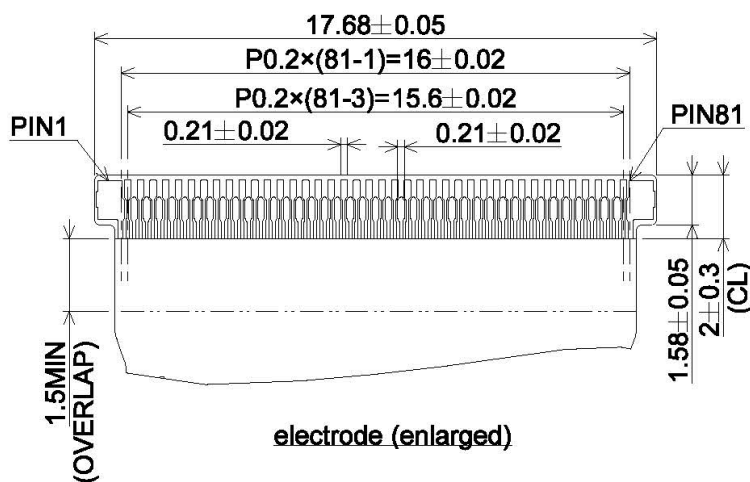

No	Description
1	FPC
2	Stiffener
3	Reinforcing material
4	End-face coating

19. Marking Specification

To make sure traceability, following marks are recorded.

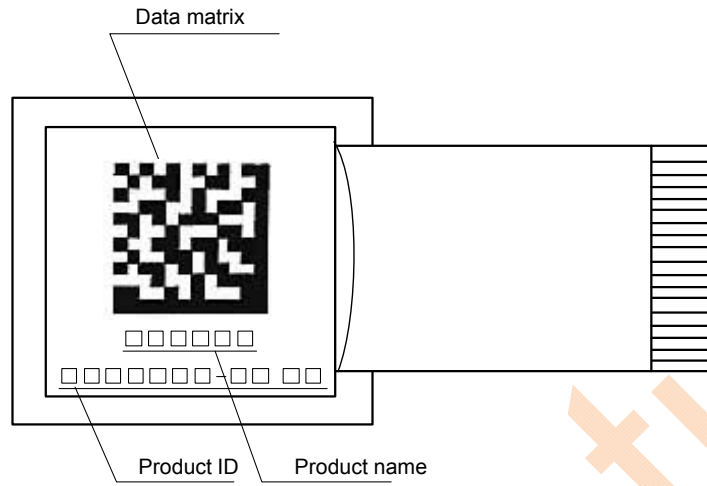

Product ID

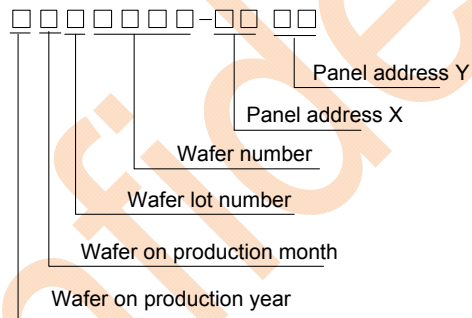

20. Packing Specification

Tray design: Soft type

Number of panel module in tray : 15 pcs

Number of tray in Carton: 14 sheets

Number of panel module in carton : 15 pcs × 14 sheets = 210 pcs

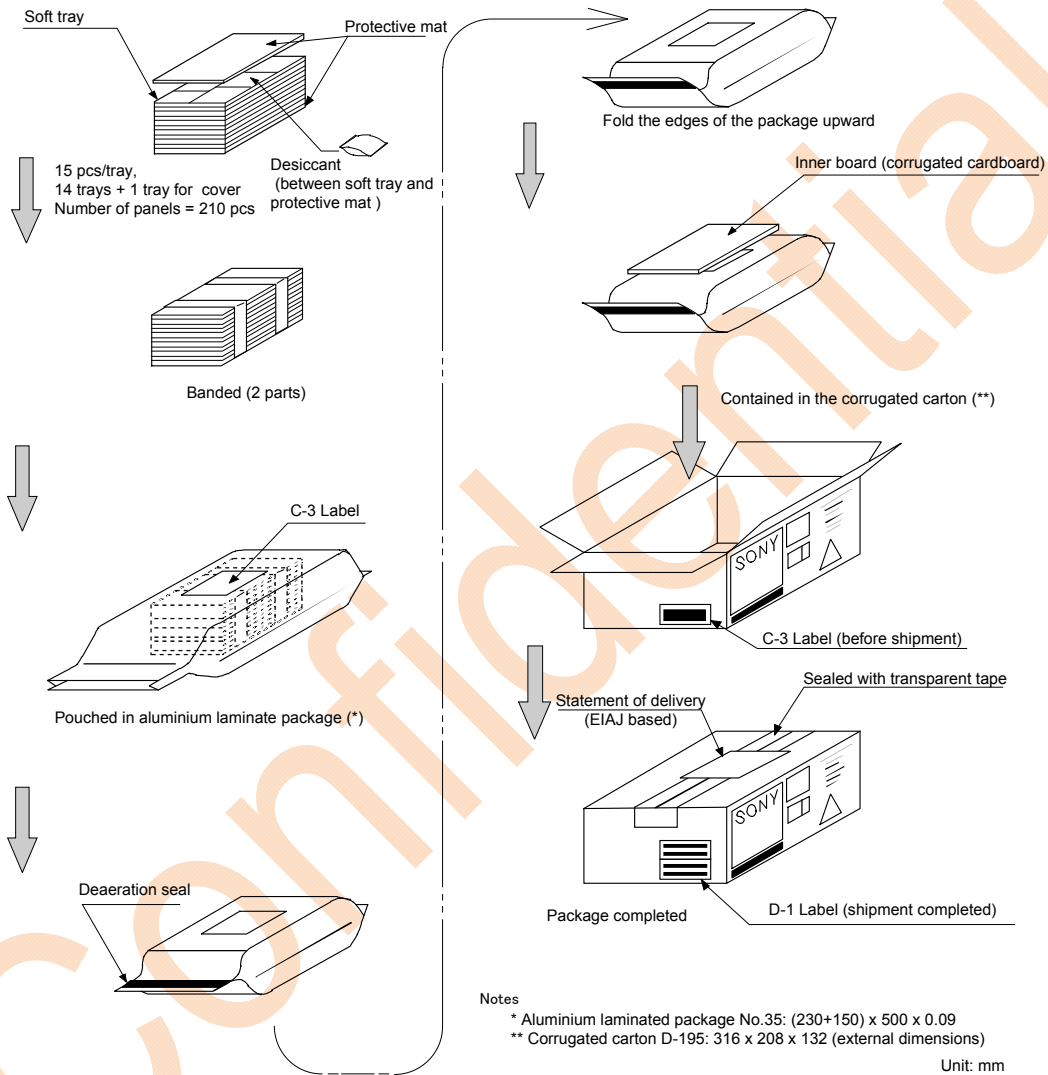

21. Recommended Items

21.1. Suppression of the Panel Temperature

Temperature of organic EL panel tends to rise due to power consumption (heat generation) by the EL emissive layer and the integrated silicon drive circuits. The temperature rise may cause luminance drop over time.

The temperature rise in panel can be suppressed by establishing a thermal connection between panel rear surface (silicon substrate surface) and metal (chassis, frame, etc.) at panel mount area. So, highly recommend the heat conductive sheet between them as show in below.

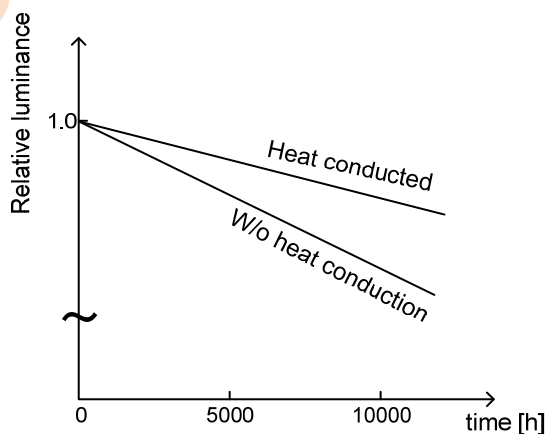
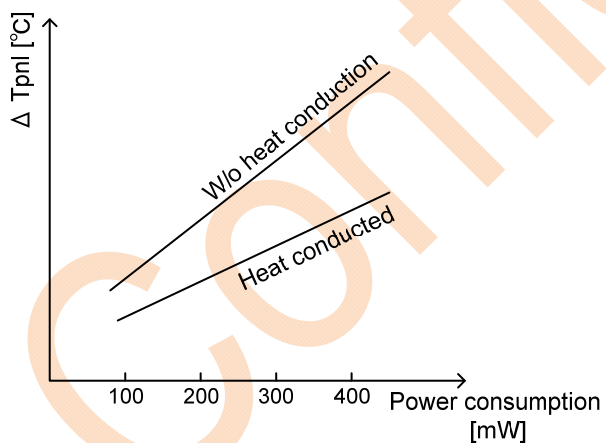
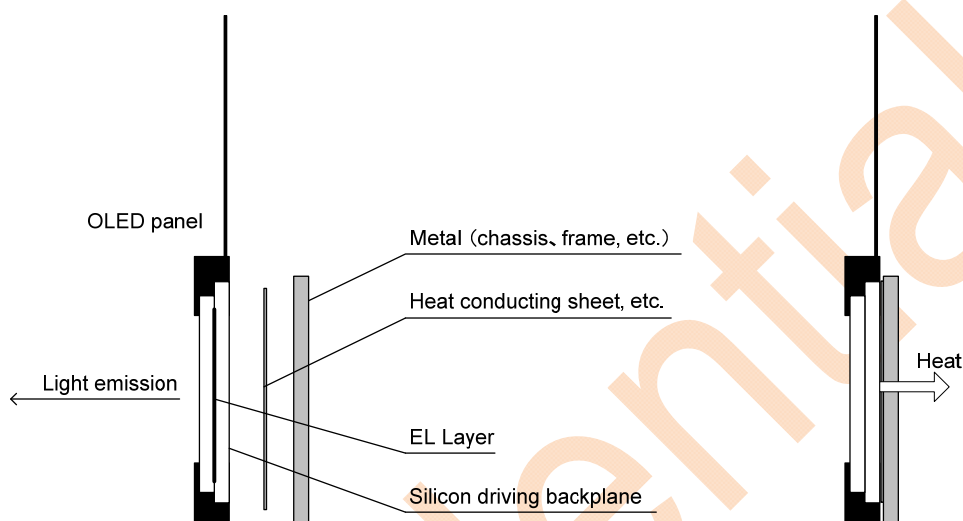

22. Notes on handling module

22.1. Static charge prevention

Be sure to take the following protective measures. Organic EL panels are easily damaged by static charges.

- (1) Use non-chargeable gloves or handle with bare hands.
- (2) Use a wrist strap connecting ground when handling.
- (3) Do not touch any electrodes on the panel.
- (4) Wear non-chargeable clothes and conductive shoes.
- (5) Install grounded conductive mats on the working floor and working table.
- (6) Keep the panel away from any charged materials.

22.2. Protection from dust and dirt

- (7) Operate in a clean environment.
- (8) Do not touch the panel surface. The surface is easily scratched.
When cleaning on panel surface, use a clean-room wiper with isopropyl alcohol. Be careful not to leave stains on the surface.
- (9) Use ionized air to blow dust off the panel surface.

22.3. Others

- (10) Not hold FPC (Flexible Printed Circuit), not twist the FPC, not bend FPC because connection area between the FPC and panel is easily broken by mechanical stress.
- (11) The minimum fold radius of the FPC is 1.0 mm, So, do not fold the FPC less than 1.0mm radius.
- (12) Do not drop the module.
- (13) Do not twist or bend the module.
- (14) Keep the module away from heat sources.
- (15) Do not expose the module to water or other solvents.
- (16) Do not store or use the module at high temperatures or high humidity circumstance, as the circumstance may affect module specifications.
- (17) When disposing of this, please regard it as industrial waste and please comply with related regulations.
- (18) Do not store or use the panel in reactive chemical substance (including alcohol) environments, as these may affect the specifications.
- (19) This module is supposed to be delivered in a degassed aluminum laminated bag.
When storing this panel again after once unsealing the bag, please take following action. Put it into the aluminum laminated bag again. Put in desiccant into the aluminum bag and the opening of the aluminum bag should be folded and seal the bag with tape.

23. Notice

Purpose of Use of the Products:

Customer shall use the Products with the utmost concern for safety, and shall not use the Products for any purpose that may endanger life or physical wellbeing, or cause serious damage to property or the environment, either through normal use or malfunction.

Use of the Products for purposes other than those stipulated in this specification is strictly prohibited.

Furthermore, usage of the Products for military purposes is strictly prohibited at all times.

Safe Design:

- ◆ Customer is responsible for taking due care to ensure the product safety design of its products in which the Products are incorporated, such as by incorporating redundancy, anti-conflagration features, and features to prevent mis-operation, in order to prevent accidents resulting in injury, death, fire, or other social damage as a result of failure.

Product Information:

- ◆ The product specifications, circuit examples, and any and all other technical information and content contained in this specification, as well as any other information and materials provided to Customer in connection with the Products (collectively, "Product Information") have been provided to Customer for reference purpose only, and the availability and disclosure of such Product Information and its usage by Customer shall not be construed as giving any indication that Sony, its subsidiaries and/or its licensors will license any right, including intellectual property rights in such Product Information by any implication or otherwise.
- ◆ Furthermore, even if circuit examples are included in this specification, they are provided only for reference purpose only, and are merely examples of application. Sony, its Subsidiaries and/or their authorized representatives shall not be liable for any damage arising out of their usage.

EXCLUSION OF WARRANTY ON THE PRODUCTS:

- ◆ UNLESS OTHERWISE NOTIFIED BY US IN WRITING, OTHERWISE AGREED BETWEEN THE CUSTOMER AND JK Electronics SUBSIDIARIES OR ANY OF THEIR AUTHORIZED REPRESENTATIVES IN WRITING, OR TO THE EXTENT PERMITTED BY LAW, THE FOLLOWING TERMS AND CONDITIONS SHALL APPLY TO THE USAGE OF THE PRODUCTS AND THE PRODUCT INFORMATION:

THE PRODUCTS AND THE PRODUCT INFORMATION ARE PROVIDED BY JK Electronics SUBSIDIARIES AND/OR THEIR AUTHORIZED REPRESENTATIVES "AS IS" AND WITHOUT WARRANTY OF ANY KIND AND JK Electronics SUBSIDIARIES AND/OR THEIR AUTHORIZED REPRESENTATIVES MAKE OR HAVE MADE NO REPRESENTATION OR WARRANTY, EXPRESS OR IMPLIED, STATUTORY OR OTHERWISE, AND EXPRESSLY DISCLAIMS ANY REPRESENTATION OR WARRANTY (I) WITH RESPECT TO ACCURACY, RELIABILITY, VALUE, UTILITY OR SAFETY OF THE PRODUCTS AND THE PRODUCT INFORMATION, OR THE ABILITY OF CUSTOMER TO MAKE USE THEREOF, (II) WITH RESPECT TO ANY IMPLEMENTATION OF THE PRODUCTS AND THE TECHNICAL INFORMATION; (III) WITH RESPECT TO MERCHANTABILITY OR FITNESS FOR A PARTICULAR PURPOSE; OR (IV) THAT THE PRODUCTS AND THE PRODUCT INFORMATION OR ANY IMPLEMENTATION THEREOF IS OR WILL BE FREE FROM INFRINGEMENT, MISAPPROPRIATION OR VIOLATION OF ANY INTELLECTUAL PROPERTY RIGHT OR ANY OTHER RIGHT OF ANY THIRD PARTY, AND ANY EQUIVALENTS OF ANY OF THE FOREGOING UNDER THE LAWS OF ANY JURISDICTION.

CUSTOMER HEREBY ACKNOWLEDGES AND AGREES THAT USE OF THE PRODUCTS AND THE PRODUCT INFORMATION IS AT CUSTOMER'S SOLE RISK AND THAT CUSTOMER IS RESPONSIBLE FOR THE USE OF THE PRODUCTS AND THE PRODUCT INFORMATION, INCLUDING DEFENDING ANY INFRINGEMENT CLAIM MADE AGAINST THE CUSTOMER IN RELATION WITH CUSOMTER'S USAGE OF THE PRODUCTS AND TECHNICAL INFORMATION.

NO ORAL OR WRITTEN INFORMATION OR ADVICE GIVEN BY JK Electronics SUBSIDIARIES OR THEIR AUTHORIZED REPRESENTATIVES SHALL CREATE A WARRANTY, DUTY OR CONDITION OR IN ANY WAY INCREASE THE SCOPE OF THIS WARRANTY.

LIMITATION OF LIABILITY:

- ◆ TO THE EXTENT PERMITTED BY LAW, JK Electronics, ITS SUBSIDIARIES AND/OR THEIR AUTHORIZED REPRESENTATIVES SHALL NOT BE LIABLE FOR ANY INCIDENTAL OR CONSEQUENTIAL DAMAGES FOR BREACH OF ANY EXPRESS OR IMPLIED WARRANTY, BREACH OF CONTRACT, NEGLIGENCE, STRICT LIABILITY OR UNDER ANY OTHER LEGAL THEORY RELATED TO THE PRODUCTS AND PRODUCT INFORMATION, INCLUDING, BUT NOT LIMITED TO, ANY DAMAGES ARISING OUT OF LOSS OF PROFITS, LOSS OF REVENUE, LOSS OF DATA, LOSS OF USE OF THE PRODUCTS OR ANY ASSOCIATED HARDWARE, DOWN TIME AND USER'S TIME, EVEN IF ANY OF THEM HAVE BEEN ADVISED OF THE POSSIBILITY OF SUCH DAMAGES.

Compliance with Laws:

- ◆ Customer shall comply with all applicable laws, ordinances, rules and regulations in connection with the usage of the Products, including the export control laws or regulations of various countries and shall be fully responsible for obtaining approvals in connection with the export of the Products in accordance with such said laws, ordinances, rules and/or regulations.

Governing Law:

- ◆ This specification and the terms and conditions contained herein shall be governed by and construed in accordance with the laws of Japan, without reference to principles of conflict of laws or choice of laws. All controversies and disputes arising out of or relating to this specification and the terms and conditions contained herein shall be submitted to the exclusive jurisdiction of the Tokyo District Court in Japan as the court of first instance.

Notes:

- ◆ The product specifications, circuit examples, technical information and any and all other information and content relating to the Products contained in this specification may be revised or updated by Sony at Sony's sole discretion without prior notice to the Customer and Customer shall abide by their latest versions. Such revisions or updates will be made available to Customer in a way as Sony deems appropriate.
- ◆ Ensure that you have read and reviewed the notices contained in our delivery specification as well as this specification when purchasing and using the Products.